

 **MITSUBISHI  
ELECTRIC**  
ENERGY RECOVERY VENTILATORS

*Changes for the Better*

**M**itsubishi  
**E**lectric  
**Q**uality

MODEL

**RX5 SERIES**

 **Lossnay**



**Concentrating what we can do.  
more, ever and definitely...**



# Simple and Effective

Excellent air quality  
and unbeatable  
Heat Exchange Efficiency

Try blowing into a rolled up piece of paper.  
The warmth of your breath travels through  
the paper to your hands.

Some 38 years ago, that simple principle led to the development  
of our most advanced air-conditioning technology.

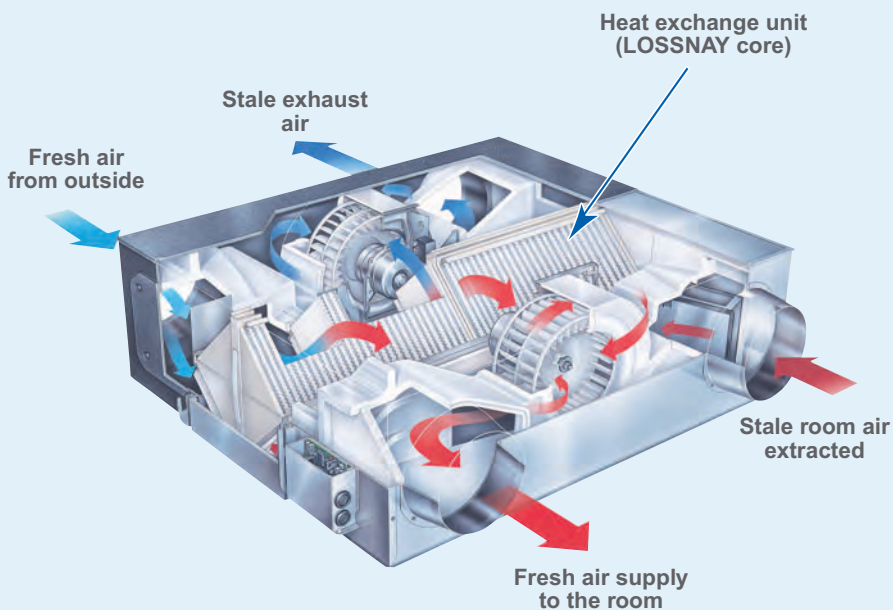

Poor air quality can be attributed to many problems arising in the workplace or in the home. It is believed to contribute to a significant loss in productivity, low morale and higher rates of sickness among many employees. The object of providing good ventilation alongside air condition in residential and commercial buildings is to provide conditions under which people can live and work comfort and safety.

Developed and refined over the past 30 years, the LOSSNAY system has perfected the recovery of waste energy. The units reduce overall energy costs by extracting stale air and then recovering the heating or cooling energy to either warm and cool incoming fresh air. By utilising this energy, the LOSSNAY system can save up to 30% on initial capital costs of heating and cooling plant.

# LOSSNAY's Energy Recovery Technology and Simultaneous Ventilations (Supply and Exhaust) Contribute to Excellent Indoor air Quality and Significantly Reduce the Outdoor air load.

## Energy-Recovery Concept by Hyper Eco LOSSNAY Core

**In summer**  
 Temperature difference between air supply and room: 1.7 °C

**In winter**  
 About 4kg/h of water vapor is recovered.

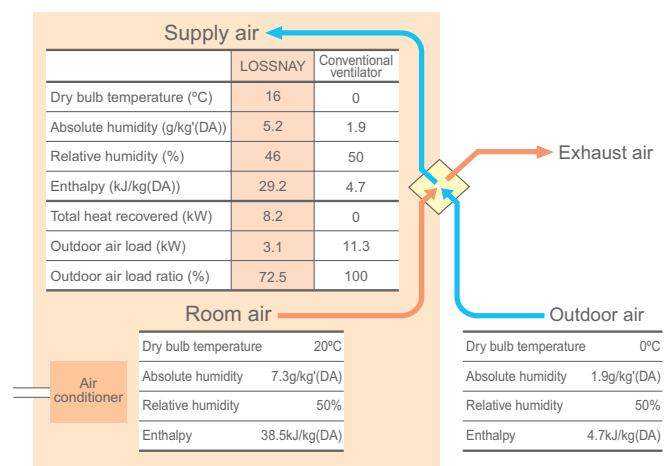
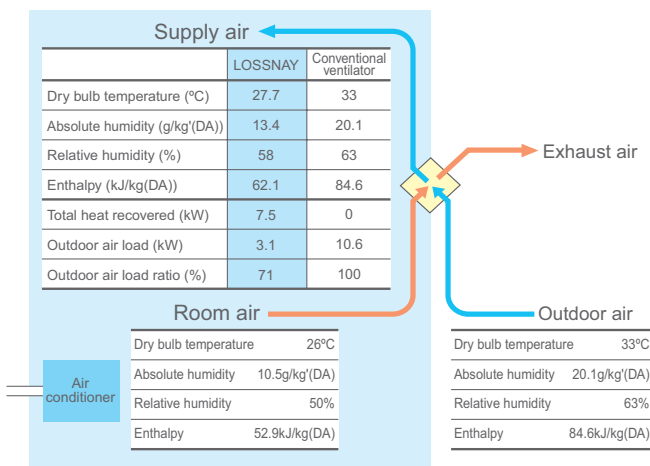

Energy-recovery calculating equation  
 Indoor supply-air temperature (°C) = Outdoor temperature (°C) - { Outdoor temperature (°C) - Indoor temperature (°C) } × Temp recovery efficiency (%)  
 Calculation example : 27.7°C=33°C-(33°C - 26°C) × 76%  
 \* The above applies to the case of LGH-100RXs (High notch).

Energy-recovery calculating equation  
 Indoor supply-air temperature (°C) = { Indoor temperature (°C) - Outdoor temperature (°C) } × Temp recovery efficiency (%) + Outdoor temperature (°C)  
 Calculation example : 16°C=(20°C - 0°C) × 80% + 0°C

Every building needs a supply of fresh air to keep its inhabitants healthy and comfortable. Outdoor air though is rarely, if ever, the same temperature as that maintained by the building's air conditioning system. In the summer, it is too hot. In the winter, it is too cold. This puts added stress on the air conditioner to compensate for the intake of the hot or cold air adding to the expense of operating the system. LOSSNAY all but eliminates this problem with original energy-recovery technology that uses the heat of the stale indoor air to be expelled in order to either heat or cool the incoming fresh air to a temperature much closer to the existing indoor air. This process reduces the load on the air conditioning system without cutting off the supply of vitally necessary fresh air.

### LOSSNAY Core Construction & Principle

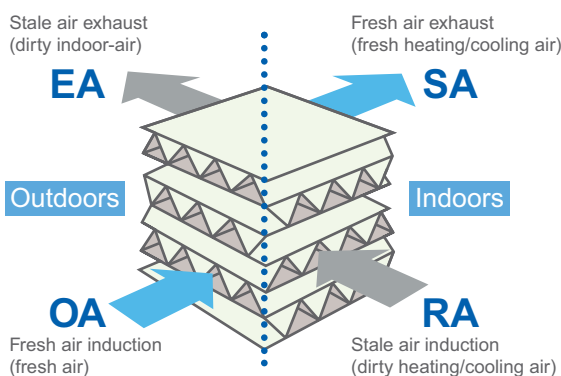

### The basic principle

The remarkable technology that permits the intake of fresh air with minimal loss to indoor temperature is known as the LOSSNAY Core. The cross-flow, plate-fin structure of the energy-recovery unit along with a specially processed diaphragm keep supply and exhaust air separate, ensuring that only fresh air is introduced to the indoor environment while also allowing for the efficient transfer of heat.

### The improvements

The microscopically small pores of the diaphragm have been made even smaller, decreasing the rate at which water soluble gases such as ammonia and hydrogen pass through. Further, a new specially processed paper used to make the diaphragm has been developed with high moisture permeability characteristics that aid in the transference of moisture for improved energy exchange efficiency. These developments further improve moisture permeability and effectiveness in shielding unwanted gases, resulting in a lower rate of gas transference and more highly efficient energy transfer.

# Hyper Eco Core

Better energy conservation by improved total heat exchange efficiency.

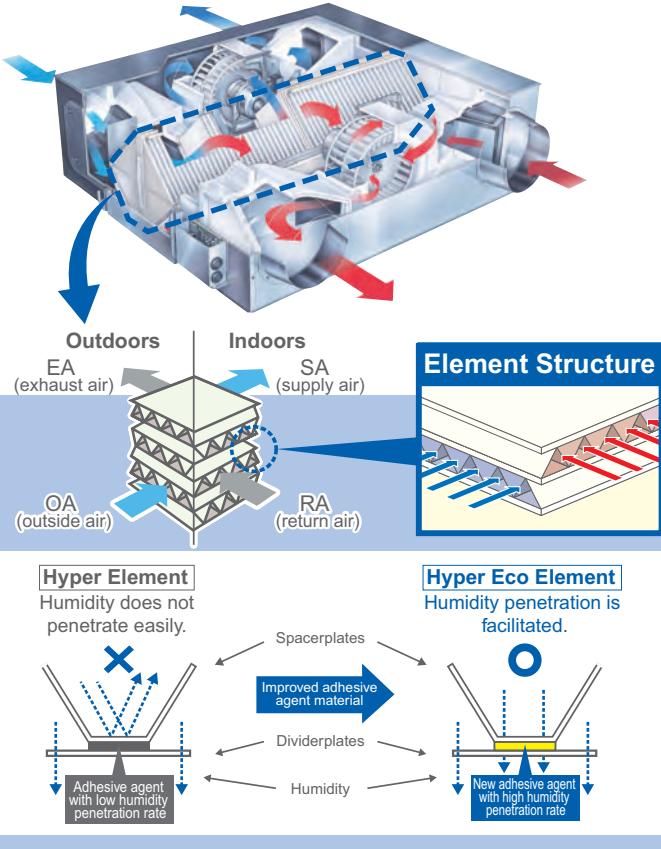

## Introducing the new Hyper Eco Element

Mitsubishi's newly developed Hyper Eco Element is on board, offering the industry's best total heat exchange efficiency. Energy conservation performance has been improved not only by reducing the air conditioning load associated with ventilation, but also by facilitating humidity penetration.

Enthalpy exchange efficiency improve

\*Cooling, High Fan speed, 50Hz

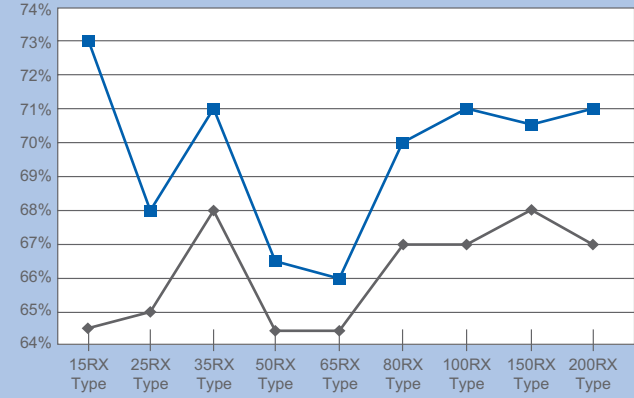

# Extra Low Mode

Additional energy conservation by using a four-level air volume system that allows more precise control.

In addition to the conventional Extra High, High, and Low modes, an Extra Low mode is added to provide a more dynamic range of air volume settings and versatility in a variety of installation environments, yielding much better energy conservation. Using a simplified timer function, it switches to Extra Low operation when the operation stop button is activated and it is accordingly possible to implement 24-hour energy conservation ventilation.

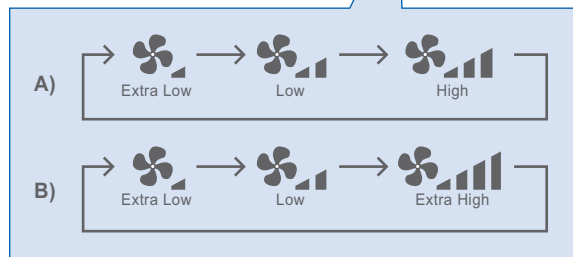
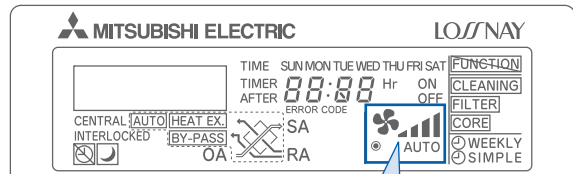

\* The Extra High and High ventilation modes are selectable by the initial setting.  
 \* Extra-Low not equipped LGH-150RXs and 200RXs.  
 \* The ventilation mode is actually selected in three levels, and the remote controller also displays these three levels.

# New function: "By-pass" Ventilation External Control Setting

In addition to the automatic damper open/close function, open/close control via external devices is now possible, delivering a "By-pass" ventilation system that is suitable to the installed environment.

### Control devices (example)

- Temperature sensor
- Humidity sensor
- Timers

### "By-pass" operation

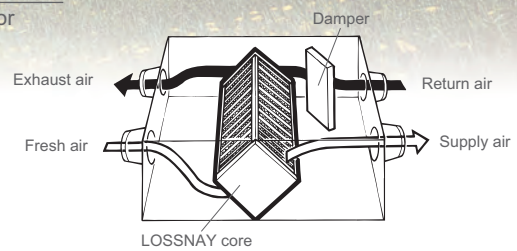

Establish the wire connection by inserting the optional remote display adaptor (PAC-SA88HA-E) in the connector CN16 (Ventilation mode selector).

With SW1 is "ON", the ventilation mode of LOSSNAY is changed to the By-pass ventilation regardless of the setting on the remote controller.

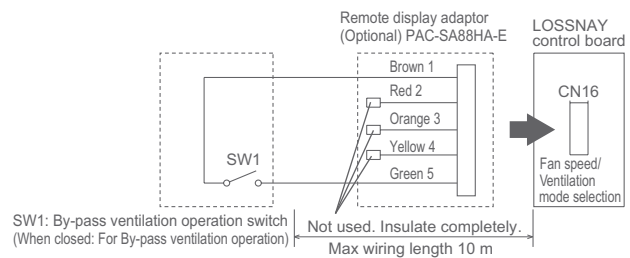

## Automatic ventilation setting

The automatic damper mode automatically provides the correct ventilation for the conditions in the room. The following shows the effect "By-pass" ventilation will have under various conditions.

### 1. Reduces cooling load

If the air outside is cooler than the air inside the building during the cooling season (such as early morning or at night), "By-pass" ventilation will draw in the cooler outside air and reduce the cooling load on the system.

### 2. Night purge

"By-pass" ventilation can be used to release hot air from inside the building that has accumulated in buildings a business district during the hot summer season.

### 3. Office equipment room cooling

During cold season, fresh air can be drawn in and used as is to cool rooms where the temperature has risen due to the use of office equipment.

\* When the outdoor air temperature drops lower than 8°C it changes to the heat exchange ventilation. (Display of the remote controller does not change)

\* In the case of "By-pass" ventilation, the supply air temperature slightly rises more than the outside air temperature because of the heat effect around the ducts or the unit motors.

# CO<sub>2</sub> Sensor



The system allows you to measure CO<sub>2</sub> density and thereby control the amount of fresh air supplied. By connecting a CO<sub>2</sub> sensor to the connector CN16, which is added to the LOSSNAY main unit, the setting

can be switched to High, Low, or Extra Low operation, which is selected when the sensor is turned ON. This system produces additional energy conservation.

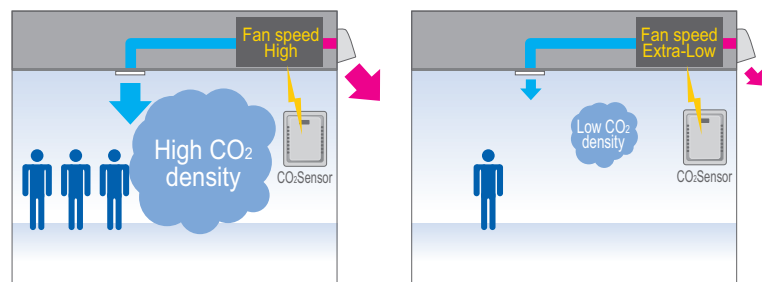

## Air volume can be set using a pin position.

To force High fan speed externally

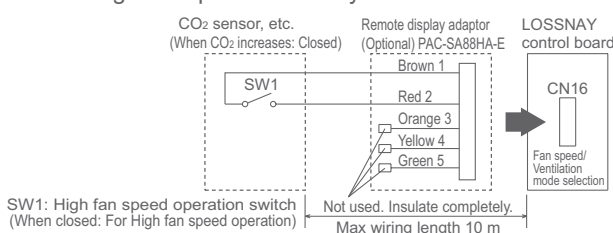

When SW1 is "ON", fan speed of the LOSSNAY will be set to "High"(Extra-High) regardless of the remote control setting. Use this in such a way that it ventilates at Low or Extra-Low fan speed normally, and when the external sensor detects contamination of indoor air, it changes to High (Extra High) fan speed operation.

# Multi-ventilation Mode enables the appropriate supply/exhaust balance to be selected to suit the usage environment and location

Featuring "Multi-ventilation Mode," which allows the air supply/exhaust balance to be varied dynamically. The supply/exhaust balance can be selected to suit the usage environment and location, such as allowing for air exhausted via extractor fans. Modes can be selected easily by setting the connectors on the circuit board.

Control switch (Hand-held remote control for microprocessor type)	Ventilation mode	Supply airflow	Exhaust airflow	Unit setting <sup>(*)</sup> (Factory setting is "High" for both supply and exhaust.)	
				Air supply	Air exhaust
High	Power air supply/exhaust mode	High	High	High	High
	Power air supply mode	High	Low	High	Low
	Power air exhaust mode	Low	High	Low	High
Low	Energy-saving ventilation mode	Low	Low	Air supply and exhaust are "Low" irrespective of unit setting.	

\* "High notch" can also be further set to "Extra High" using the unit switch.

**Offers choice of 9 air supply/exhaust combination patterns.**

## Normal office, etc.



Providing efficient ventilation while maintaining air supply/exhaust balance...

**Power air supply /exhaust**

## Smaller offices or tenant buildings, etc.



Using LOSSNAY compensates for using extractor fans...

**Power air supply**

## Smoking areas, etc.



Priority on air exhaust...

**Power air exhaust**

## New Remote Controller PZ-60DR-E

A new remote controller for the RX5 series is now available. In addition to boosting the energy conservation performance of the main unit, the remote controller features a variety of new functions which also pursue additional energy conservation. The appearance of the remote controller conforms to Mitsubishi air conditioner interface design standards. Functions that were set using Dip-Switch on the LOSSNAY main unit can now be configured as needed using the new remote controller. This eliminates the need to crawl under the eaves to change operation settings. Also, a newly adopted dot matrix display provides much more information, making it easy to check maintenance indications, operation status display, and explanations required when configuring settings.

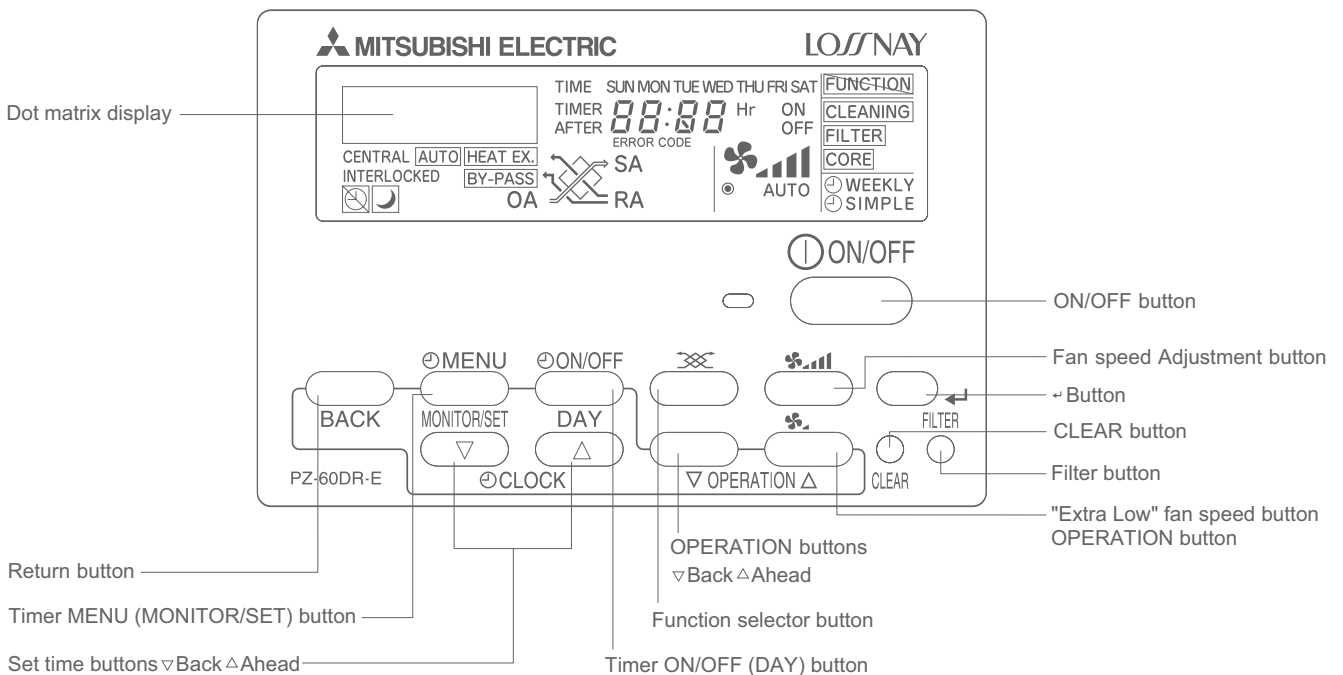

# Newly Adopted Dot Matrix Display Available in Eight Languages

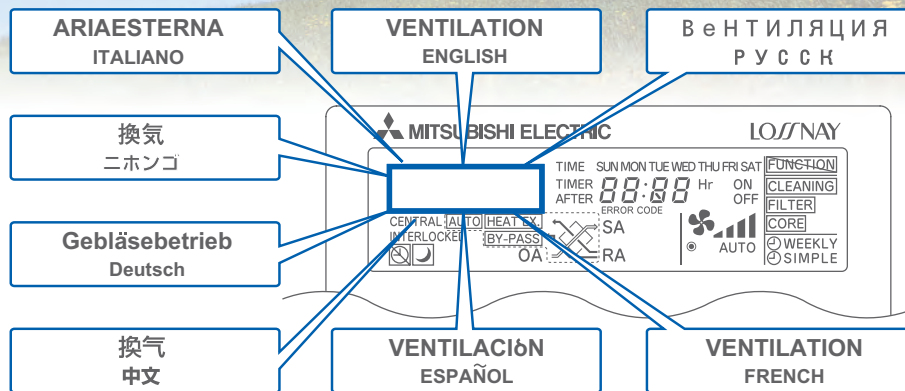

## Energy Saving by WEEKLY timer

Air volume level can be set hourly (max 8 times) and weekly. You can pre-set air volume according to the predictable requirement so that LOSSNAY can automatically operate at only necessary air-speed at the specified time period, which saves power consumption while maintaining the indoor air quality. Besides, once the weekly timer has been set, no switching on-off is required.

### Example A (Hourly)

current RX<sub>4</sub> series with PZ-41SLB controller



new RX<sub>5</sub> series with PZ-60DR-E



Total power consumption in one day : LGH-100RX<sub>4</sub>-E : 6,600W (14 hours)  
 LGH-100RX<sub>5</sub>-E : 5,390W (14 hours) → **1,210W (18%) less**

### Example B (Weekly)

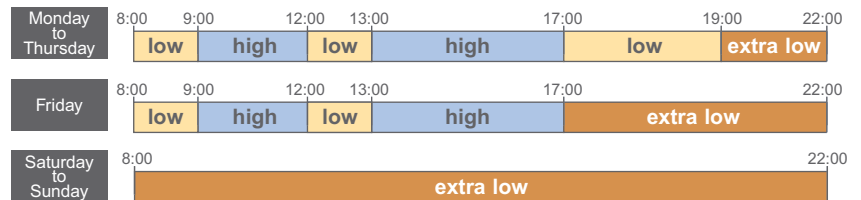

## Energy Saving by Night Purge Function

During the summer season, the Night Purge function draws cooler outside air into the room to suppress temperature rises at night. This energy conservation function reduces the load when air conditioning is started the next morning.

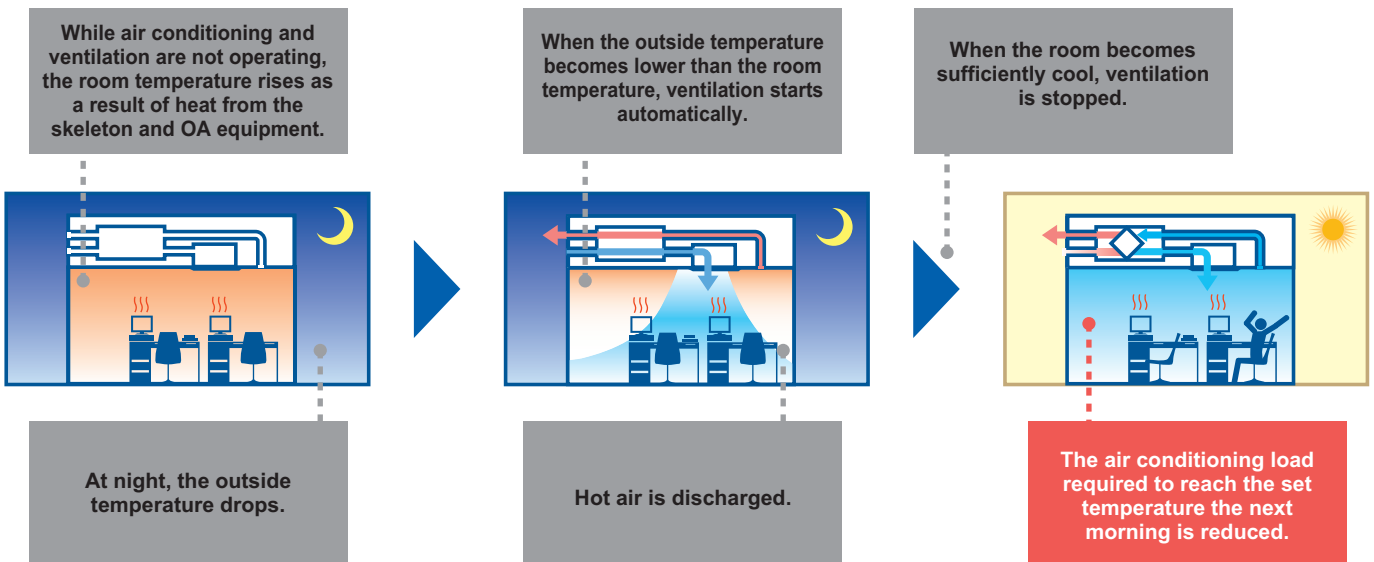

The out door temperature (OA) setting can be selected either 17°C or 28°C by using Dip-Switch (SW2-7) in the LOSSNAY control box. Refer to the Installation Manual for more information.  
 \*Do not use the night purge function if fog and heavy rain is expected. The entry of rain water may occur in the night.

# Control

## The New Remote Controller PZ-60DR-E enable simple control setting

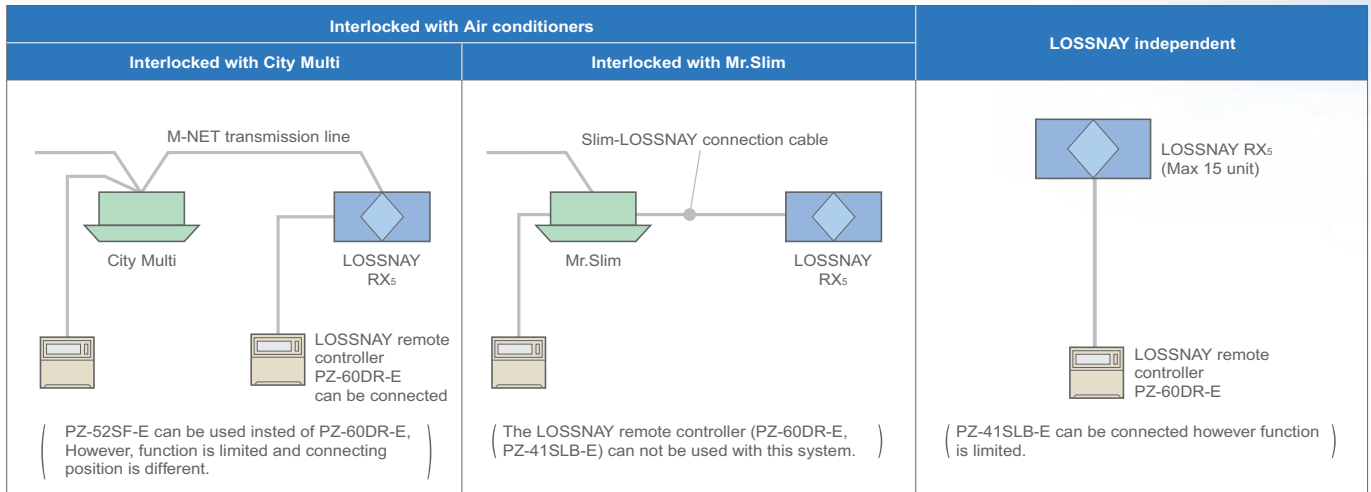

## Centralized Controller System

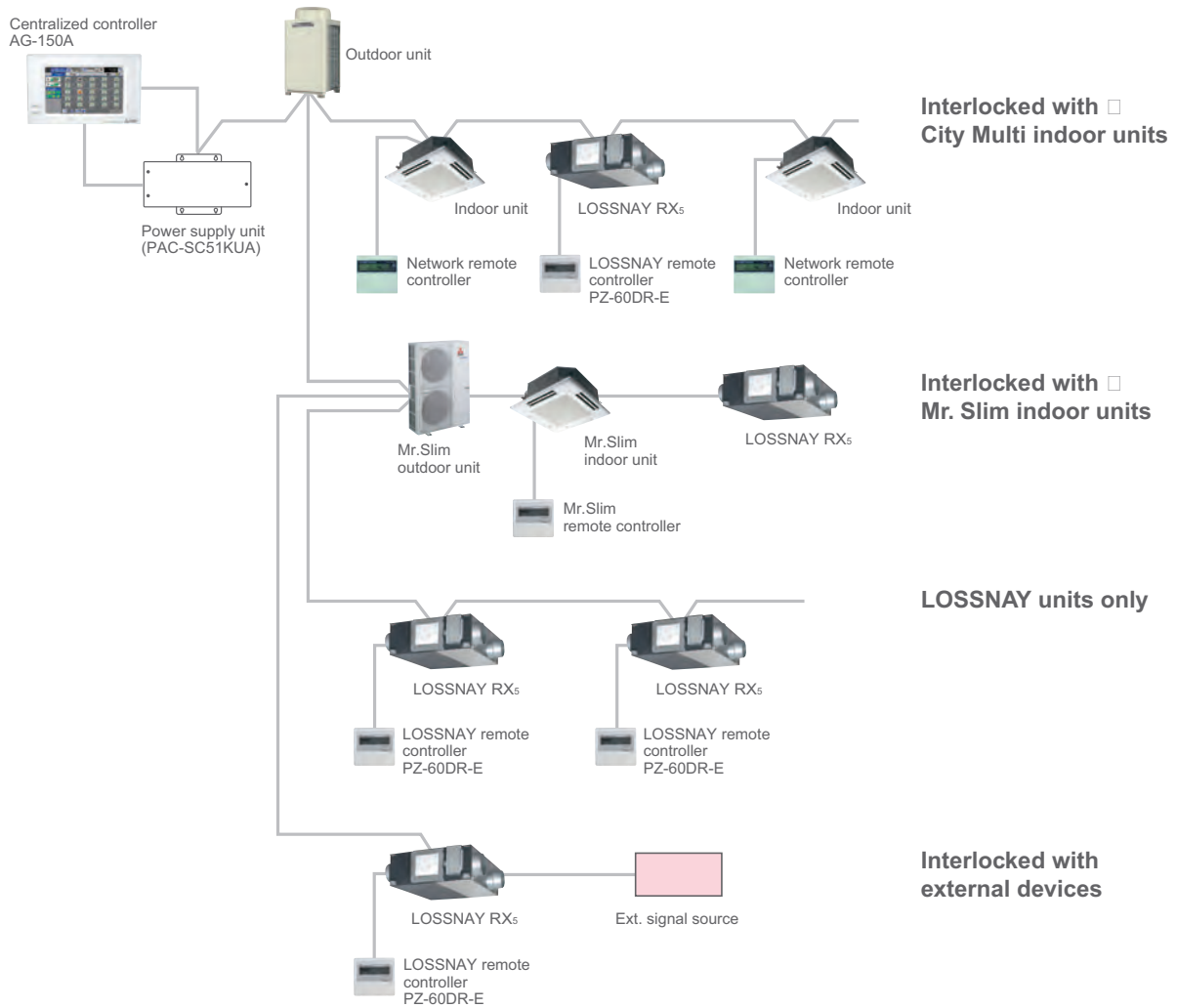



# Can Be Used With AG-150A Centralized Controller

Controllers are one of the most important and familiar devices in an air conditioning system. Not only does it control to provide optimum air environment but supports operations to minimize running costs and to preserve energy. Through studies and development, we've visualized a new system controller meeting needs with versatile options.

With a new coloured touch panel, new functions, and continuation of all the current G-50A functions, AG-150A visualizes its functions from basic control to advanced operations and bringing an ultimate controller to reality.

– Design your control

with our new centralized controller; AG -150A.

## ■ System structure

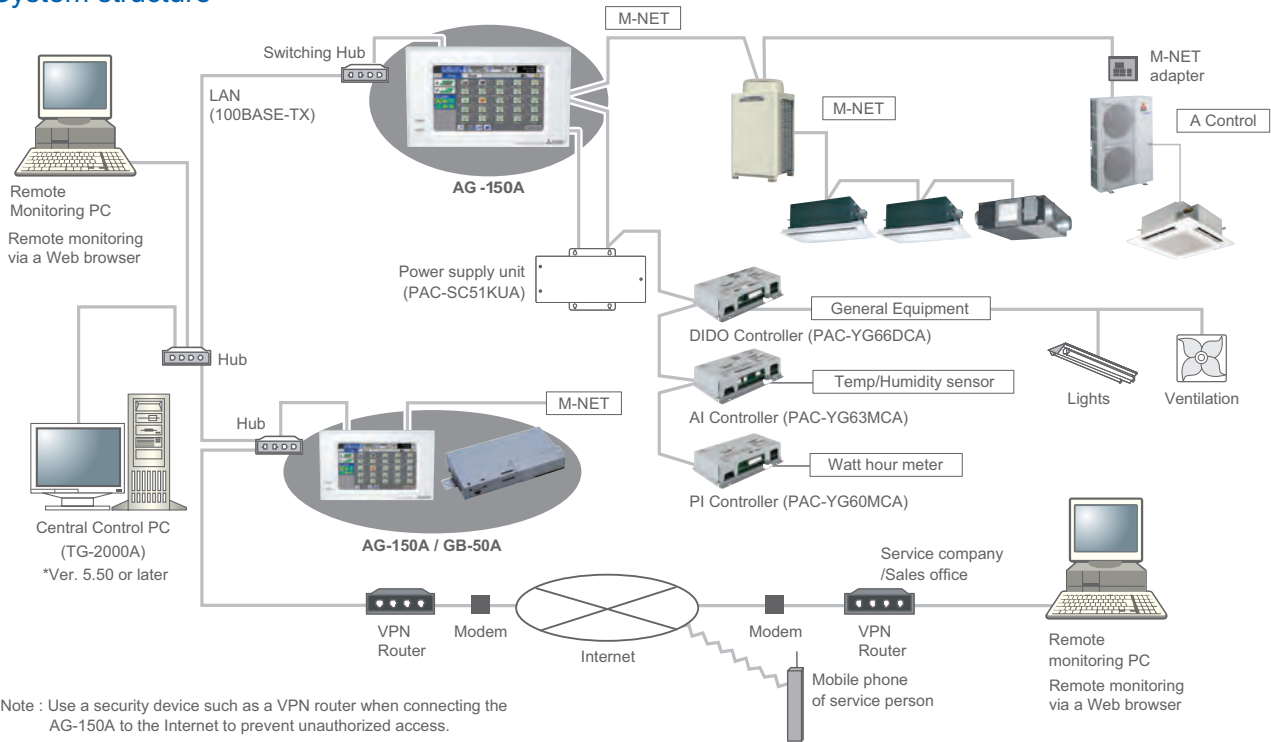

Note : Use a security device such as a VPN router when connecting the AG-150A to the Internet to prevent unauthorized access.

## Functions

□ : Each unit    ○ : Each group    ● : Each block    △ : Each floor    ◎ : Collective    X : Not available

Item	Description	Operations	Display
<b>Controllable unit</b>	Up to 50 units/groups.		
<b>ON/OFF</b>	Run and stop operation for the air conditioner units and general equipment. (To operate general equipment, PAC-YG66DCA is required.)	○ ◎ △ ●	○ ◎
<b>Operation mode switching</b>	Switches between Cool / Dry / Auto / Fan / Heat. (Group of LOSSNAY unit : automatic ventilation/ vent - heat interchange/ normal ventilation) depending on the air conditioner unit. Auto mode is for City Multi R2 and WR2 series only.	○ ◎ △ ●	○
<b>Temperature setting</b>	Cool/Dry : 19°C (67°F) - 30°C (87°F) [14°C (57°F) - 30°C (87°F)] Heat : 17°C (63°F) - 28°C (83°F) [17°C (63°F) - 28°C (83°F)] Auto : 19°C (67°F) - 28°C (83°F) [17°C (63°F) - 28°C (83°F)] [ ] in case of using middle-temperature on PDFY, PEFY-VML/VMR/VMS/VMH-by setting DipSW7-1 to ON. Yet, PEFY-P-VMH-E-F is excluded.	○ ◎ △ ●	○
<b>Fan speed setting</b>	Models with 4 air flow speed settings: Hi/Mid-2/Mid-1/Low Models with 3 air flow speed settings: Hi/Mid/Low Models with 2 air flow speed settings: Hi/Low Fan speed setting (including Auto) varies depending on the model.	○ ◎ △ ●	○
<b>Air flow direction setting</b>	Air flow direction angles, 4-angle or 5-angle Swing, Auto (Louver cannot be set)	○ ◎ △ ●	○
<b>Schedule operation</b>	Weekly schedule can be set by groups based on daily operation pattern.	○ ◎ △ ●	○
<b>Permit / Prohibit local operation</b>	Individually prohibit operation of each local remote control function (Start/Stop, Change operation mode, Set temperature, Reset filter).	○ ◎ △ ●	○
<b>Indoor unit intake temperature</b>	Measures the intake temperature of the indoor unit only when the indoor unit is operating.	X	○
<b>Error</b>	When an error is currently occurring on an air conditioner unit, the afflicted unit and the error code are displayed.	X	□ ◎
<b>Test run</b>	This operates air conditioner units in test run mode.	○ ◎ △ ●	○
<b>Ventilation interlock</b>	The ventilation unit (LOSSNAY) is able to automatically start its operation when operation of the interlocked indoor unit starts.	○ ◎ △ ●	○
<b>External input/output</b>	By using optional external input/output adaptor (PAC-YG10HA) you can set and monitor the following. Input : By level signal : "Batch start/stop", "Batch emergency stop" By pulse signal : "Batch start/stop", "Enable/disable local remote controller" Output : "Start/stop", "Error/Normal"	◎	◎

\*NOTE: Operation and displayed content vary depending on the indoor unit model.



# List of Remote Controller Settings and Functions

The remote controller provides a wide range of functions and features other than the main functions described above, such as sophisticated energy conservation control and an easy to see, easy to use interface.

Function(Communicating mode)	New Controller PZ-60DR-E (V Controlling)	PZ-41SLB-E (V Controlling)	PZ-52SF-E (M-NET)
<b>New Function</b>			
Extra low fan speed (Except LGH-150RXs and 200RXs)	✓	—	—
Weekly timer	✓	—	—
Simple timer	✓	—	—
Night Purge mode	✓	—	—
Multi languages display	✓	—	—
24-hours ventilation (Except LGH-150RXs and 200RXs)	✓	—	—
Operation function limit	✓	—	—
Clock display	✓	—	—
Contact number setting for error situation	✓	—	—
LOSSNAY core cleaning sign	✓	—	—
Air volume display by external signal	✓	—	—
Bypass display by external signal	✓	—	—
<b>Possible setting from the controller in addition to unit Dip-SW setting</b>			
Extra High / High switch setting	✓	— (in unit setting)	— (in unit setting)
Multi Ventilation mode	✓	— (in unit setting)	— (in unit setting)
Power supply / exhaust when operation starts	✓	— (in unit setting)	— (in unit setting)
Pulse input	✓	— (in unit setting)	— (in unit setting)
Inter locking mode	✓	✓	— (in unit setting)
Automatic recovery following power supply interruption	✓	only auto recover mode	— (in unit setting)
Delay operation at heating or cooling start-up	✓	✓	— (in unit setting)
Operation output monitor	✓	— (in unit setting)	— (in unit setting)
Exhaust fan stop at outdoor air lower than -15°C	✓	— (in unit setting)	— (in unit setting)
Exhaust fan stop during defrosting, exhaust fan Low speed operation at outdoor air lower than -15°C	✓	— (in unit setting)	— (in unit setting)
Bypass automatic ventilation priority setting	✓	— (in unit setting)	— (in unit setting)
Filter cleaning sign	✓	✓	— (in unit setting)
<b>Maintenance display</b>			
Total operated hours	✓	—	—
Total LOSSNAY mode operated hours	✓	—	—
Error history	✓	—	—
<b>Carry on function</b>			
In the use of MELANS M-NET	✓	—	✓
2 controllers display	—	✓	—
"Central" indication(use prohibition)	✓	—	✓

## Connect ducts in two different directions (OA, EA side)

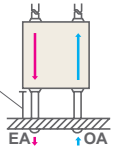
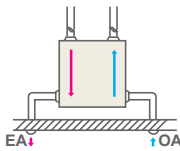
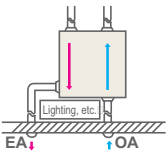
Ducts can be connected in two different directions to the outdoor vents thanks to collars and aperture plates that can be interchangeably placed in two different positions. This flexibility allows for installations close to the surface of a wall and helps avoid cases where the stale air exhaust vent would be blocked by an obstruction of some kind. This makes both planning and installation that much simpler.

Standard installation	Installation with duct direction changed	
<p>A space is necessary to prevent the influx of rainwater.</p> 	<p>Can be installed close to the surface of the wall.</p> 	<p>Avoid installations where the stale air exhaust aperture would be blocked by lighting or air conditioning units.</p> 
 <p>Collar Aperture Plate</p>	<p>Changing the duct direction</p>  <p>Exchangeable</p>	<p>Remove the collar (factory-standard direction) and the side panel aperture plate and switch their placements. They are both equipped with screw stoppers making the switch extremely simple. The direction of the ducts can only be changed on the outside (OA and EA). The inside cannot be changed (SA and RA).</p>

The position of the suspension bracket is changed to improve workability.

By attaching the suspension bracket in the center of the product, the suspension bracket does not need to be moved even when the product is mounted upside down. (Model LGH-15 to 65)

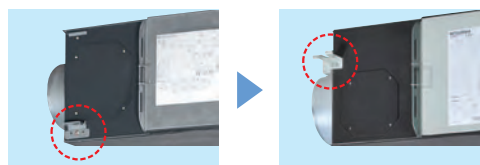

OA/EA square duct (LGH-150•200R)

OA/EA is square duct. This simplifies installation and reduces total installation time.

# Controllers

## LOSSNAY remote controller (PZ-60DR-E)

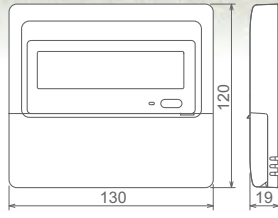

Unit: mm

Source power requirement	Power received from a LOSSNAY unit, TM4 ① - ②
Number of LOSSNAY units controlled by PZ-41SLB-E	1-15

## LOSSNAY remote controller (PZ-41SLB-E)

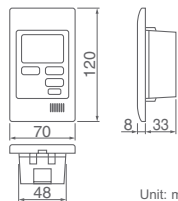

Unit: mm

\*Stock available only.

Source power requirement	Input voltage: 9VDC-15VDC, 0.02A Power received from a LOSSNAY unit, TM4 ① - ②
Interface condition for transmission line	Specialized transmission line: DC power+AM modulation
Number of LOSSNAY units controlled by PZ-41SLB-E	1-15

## LOSSNAY M-NET remote controller (PZ-52SF-E)

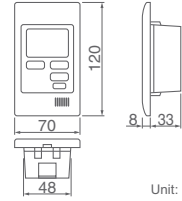

Unit: mm

\*Stock available only.

Source power requirement	Input voltage: 17VDC-30VDC, 0.02A Power received from an outdoor unit or a power supply unit via M-NET transmission line.
Interface condition for transmission line	M-NET transmission line: 30VDC+AMI signal (±5VDC)
Number of M-NET controlled LOSSNAY units controlled by PZ-52SF-E	1-16

# Filters

## Standard filter

Replacement components for the standard air filter supplied with the LOSSNAY LGH main unit.

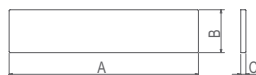

Model	Dimension (mm)			Number of filters per set		Applicable model	Filter material
	A	B	C	Supply	Exhaust		
PZ-25RF <sub>s</sub> -E	333	156	15	2	2	LGH-15RX <sub>s</sub> -E, LGH-25RX <sub>s</sub> -E	Nonwoven filter Collection efficiency (EU-G3)
PZ-35RF <sub>s</sub> -E	399	183	20	2	2	LGH-35RX <sub>s</sub> -E	
PZ-50RF <sub>s</sub> -E	470	183	15	2	2	LGH-50RX <sub>s</sub> -E	
PZ-65RF <sub>s</sub> -E	433	218	15	2	2	LGH-65RX <sub>s</sub> -E	
PZ-80RF <sub>s</sub> -E	451	243	15	2	2	LGH-80RX <sub>s</sub> -E, LGH-150RX <sub>s</sub> -E(2sets)	
PZ-100RF <sub>s</sub> -E	565	243	15	2	2	LGH-100RX <sub>s</sub> -E, LGH-200RX <sub>s</sub> -E(2sets)	

## High-efficiency filter

This high-efficiency filter (with 65% colorimetricity EU-F7) can be incorporated inside the LOSSNAY unit without the need to attach parts from other systems, as done to date. The main unit external dimensions are unchanged, and processing capacity ranges between 150m<sup>3</sup>/h and 2,000m<sup>3</sup>/h.



Model	Dimension (mm)		Number of filters per set	Applicable model	Filter material
	A	B			
PZ-25RFM	327	144	2	LGH-15RX <sub>s</sub> -E, LGH-25RX <sub>s</sub> -E	Non combustible fiber (Polyester polyolefin) (EU-F7)
PZ-35RFM	393	171	2	LGH-35RX <sub>s</sub> -E	
PZ-50RFM	464	171	2	LGH-50RX <sub>s</sub> -E	
PZ-65RFM	427	205	2	LGH-65RX <sub>s</sub> -E	
PZ-80RFM	446	232	2	LGH-80RX <sub>s</sub> -E, LGH-150RX <sub>s</sub> -E(2sets)	
PZ-100RFM	559	232	2	LGH-100RX <sub>s</sub> -E, LGH-200RX <sub>s</sub> -E(2sets)	



Incorporation into the main unit is simple, and filter changes can be performed via the main unit inspection opening.

# A Breath of Freshness in Restau

## Restaurants

**A restaurant can never be too clean and its air never too fresh**

The atmosphere of a restaurant is crucial to securing customers and making them happy enough to come back for more. Cleanliness is the key to an attractive atmosphere and restaurants devote significant effort to ensuring the premises are sanitary. Sanitation and cleanliness, however, are not enough. No matter how clean a restaurant may look, if there are bothersome odors lingering in the air, all those efforts go to waste and the restaurant's clean image is tarnished. For these reasons, we invite restaurant owners to leave the air to LOSSNAY. LOSSNAY's superior ventilation capabilities ensure that every breath is a breath of freshness keeping guests happy. LOSSNAY also keeps owners happy with its remarkable heat recovery technology that supplies fresh outdoor air with minimal change to indoor temperature, saving on energy and expense.

**If it's LOSSNAY...**

Ventilators work to exhaust stale air and supply fresh, clean air free of the odors associated with cooking, cigarettes, and the people working and dining.

Change in room temperature is kept to a minimum during ventilation thanks to the heat-recovery function.

The ventilators operate very quietly so those in the midst of enjoying their meals will not be bothered by any excess noise.

A large array of ventilators is available to match the layout of just about any restaurant.

What would you most like to see improved in restaurants?

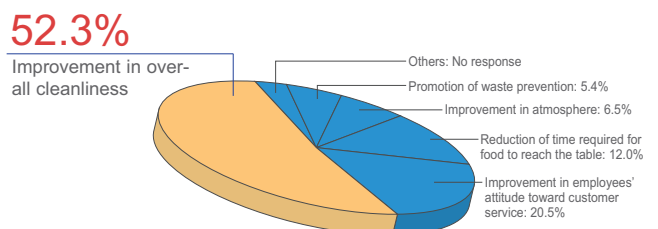

1996 Foodstuffs Consumption Monitor, Second Periodic Survey (Ministry of Agriculture, Forestry and Fisheries, Japan)



# Restaurants, Offices, and Schools

## Offices

### Fresh air—improving the overall quality of working life

Many office buildings today are heavily insulated air-tight structures with little or no natural ventilation. The unnatural environment created by air conditioners without added ventilation is a breeding ground for bacteria. Factor this in with the accumulation of pollutants and odors in the form of cigarette smoke, formaldehyde, pollen, dust, and carbon dioxide, and the necessity of ventilation becomes ever more apparent. In fact, poorly ventilated buildings can give rise to Sick Building Syndrome, a malady that is known to cause headaches, sore eyes, itching, and concentration loss. This results not only in discomfort at best and sickness at worst for the building's occupants, but also the reduced productivity of the workforce. Fresh air, effectively ventilated throughout the building, is therefore essential to the overall quality of working life.

### If it's LOSSNAY...

Simultaneous forced-air supply and exhaust introduces fresh, outdoor air into the building, effectively ventilating even fully airtight structures.

Multiple split-type units operate independently of one another, simplifying system set up and ensuring a layout that optimally matches nearly any office design.

LOSSNAY operation can be interlocked with air-conditioning system operation.

Heat that is commonly lost due to ventilation is collected and reused thanks to the LOSSNAY Core, reducing air conditioners' energy load and cutting operating costs.

## Schools

### Creating the best possible environment for our children to succeed

Children deserve all the help we can give for them to grow up healthy, happy, and prosperous. No matter how good a school's curriculum, no matter how positive and enthusiastic the teacher, a child who does not feel well will have a hard time learning. The constant flow of fresh air is nowhere as important as it is in our schools. In classrooms where large numbers of students are gathered for long periods of time, carbonic gases have the tendency to accumulate, decreasing the levels of oxygen that are vital for alertness and concentration. This is especially true during the winter months when windows tend to remain closed. LOSSNAY ventilates fresh outdoor air into classrooms to replenish the supply of oxygen and expels not only carbon dioxide, but also other pollutants and odors that inevitably sully the air.

### If it's LOSSNAY...

The continuous influx of fresh, outdoor air and the exhaust of stale, indoor air ensure that the indoor oxygen level is maintained at just the right balance for comfort and health.

Occupants have the luxury of breathing fresh air at all times even in highly air-tight buildings.

LOSSNAY's sound attenuation qualities prevent outside noise from penetrating into the room, helping to maintain a quiet environment for productive study.

Heat-exchange technology prevents fluctuations in temperature for significant energy savings when either heating or cooling a room.

### O<sub>2</sub> concentration and deficiency

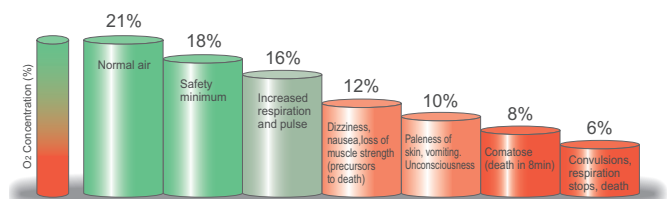

# Specifications / Dimensions

## LGH-15 to 100RX5

---



## LGH-150 and 200RX5

---



# LGH-15RX5-E

Model		LGH-15RX5-E							
Frequency / Power source		50Hz / Single phase 220-240V							
Ventilation mode		LOSSNAY ventilation				By-pass ventilation			
Fan speed		Extra High	High	Low	Extra Low	Extra High	High	Low	Extra Low
Current (A)		0.44-0.46	0.37-0.38	0.25-0.25	0.14-0.15	0.45-0.46	0.37-0.38	0.25-0.26	0.14-0.15
Power consumption (W)		96-110	80-90	53-59	30-35	97-110	81-91	54-61	30-35
Air volume	(m <sup>3</sup> /h)	150	150	110	70	150	150	110	70
	(L/s)	42	42	31	19	42	42	31	19
External static pressure	(mmH <sub>2</sub> O)	10.2-10.7	6.6-7.1	3.6-4.1	1.4	10.2-10.7	6.6-7.1	3.6-4.1	1.4
	(Pa)	100-105	65-70	35-40	14	100-105	65-70	35-40	14
Temperature exchange efficiency (%)		82.0	82.0	84.0	85.5	—	—	—	—
Enthalpy exchange efficiency (%)	Heating	75.0	75.0	77.5	81.0	—	—	—	—
	Cooling	73.0	73.0	76.5	81.0	—	—	—	—
Noise (dB) (Measured at 1.5m under the center of panel in an anechoic chamber)		27.5-28	26.5-27	22-23.5	18	28.5-29	27-28	23-24	18-19
Weight (kg)		20							
Starting current		Under 0.8A Less							

\*The Air outlets noise (45° angle, 1.5 meters in front of the unit) is about 6dB greater than the indicated value. (at High Fan speed)

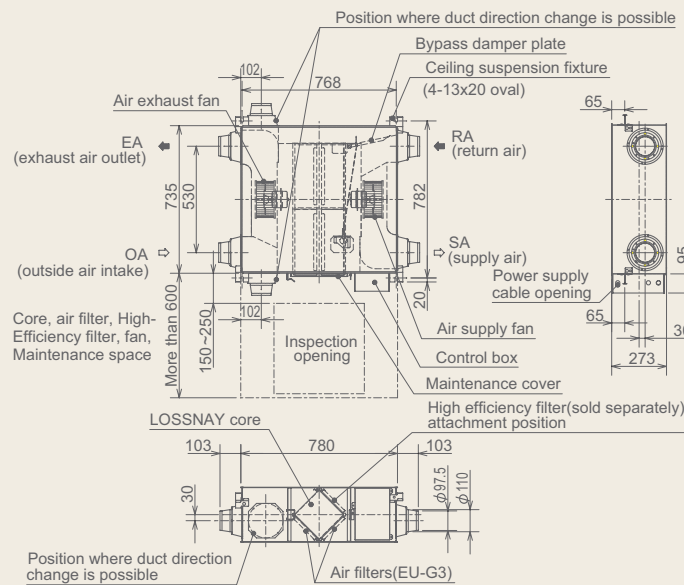
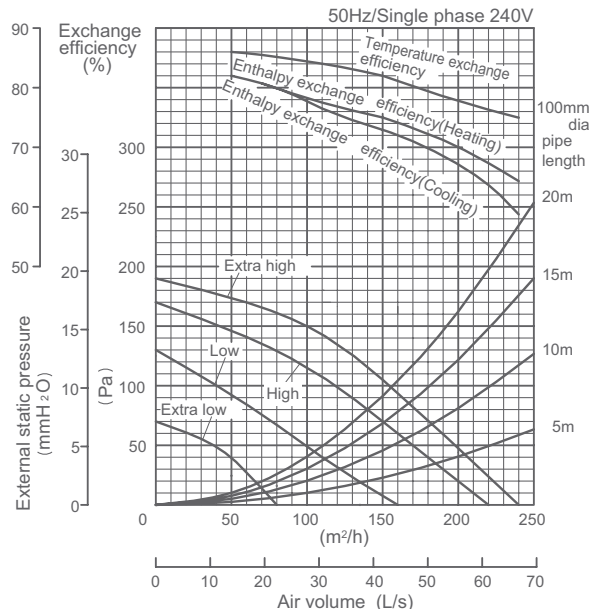
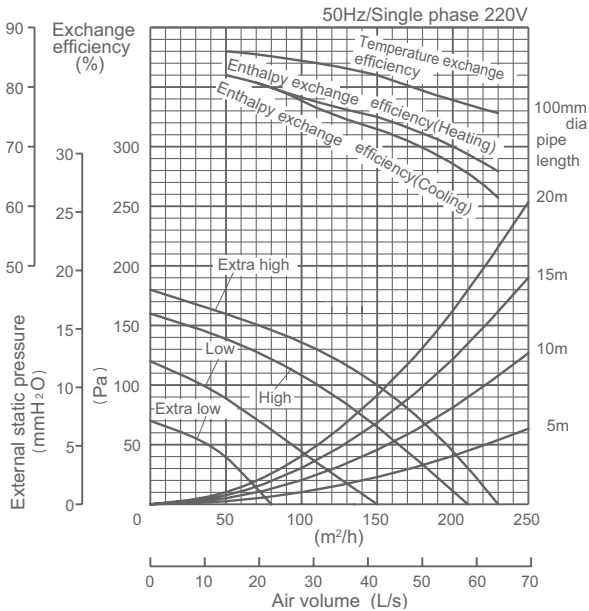

Unit: mm

# LGH-25RX5-E

Model		LGH-25RX5-E								
Frequency / Power source		50Hz / Single phase 220-240V								
Ventilation mode		LOSSNAY ventilation				By-pass ventilation				
Fan speed		Extra High	High	Low	Extra Low	Extra High	High	Low	Extra Low	
Current (A)		0.52-0.55	0.47-0.48	0.26-0.27	0.17-0.18	0.53-0.55	0.47-0.48	0.26-0.27	0.17-0.18	
Power consumption (W)		113-129	102-114	56-62	36-42	115-131	103-115	56-63	36-42	
Air volume		(m <sup>3</sup> /h)	250	250	155	105	250	250	155	105
		(L/s)	69	69	43	29	69	69	43	29
External static pressure		(mmH <sub>2</sub> O)	8.2-8.7	5.1-6.1	2-2.5	0.9	8.2-8.7	5.1-6.1	2-2.5	0.9
		(Pa)	80-85	50-60	20-25	9	80-85	50-60	20-25	9
Temperature exchange efficiency (%)		79.0	79.0	81.5	83.5	—	—	—	—	
Enthalpy exchange efficiency (%)		Heating	69.5	69.5	74.0	77.5	—	—	—	—
		Cooling	68.0	68.0	72.5	76.0	—	—	—	—
Noise (dB) (Measured at 1.5m under the center of panel in an anechoic chamber)		26-27	25-26	20-21.5	18-19	26.5-27.5	25.5-26.5	20.5-22	18-19	
Weight (kg)		20								
Starting current		Under 0.9A Less								

\*The Air outlets noise (45° angle, 1.5meters in front of the unit) is about 10dB greater than the indicated value.(at High Fan speed)

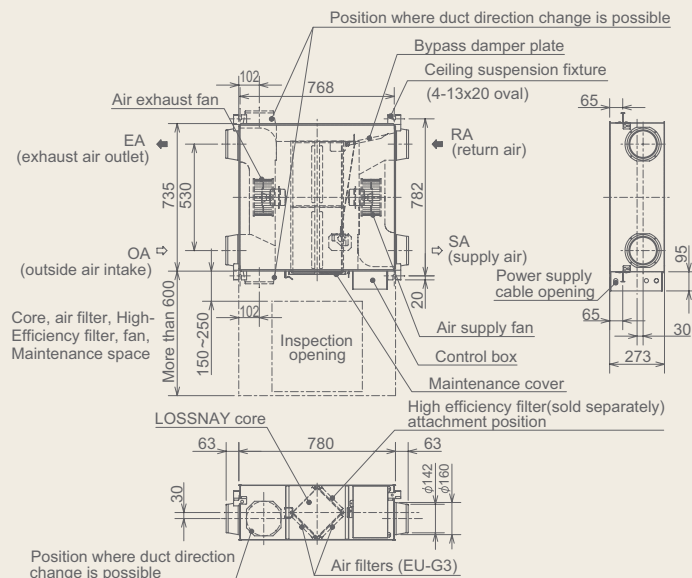
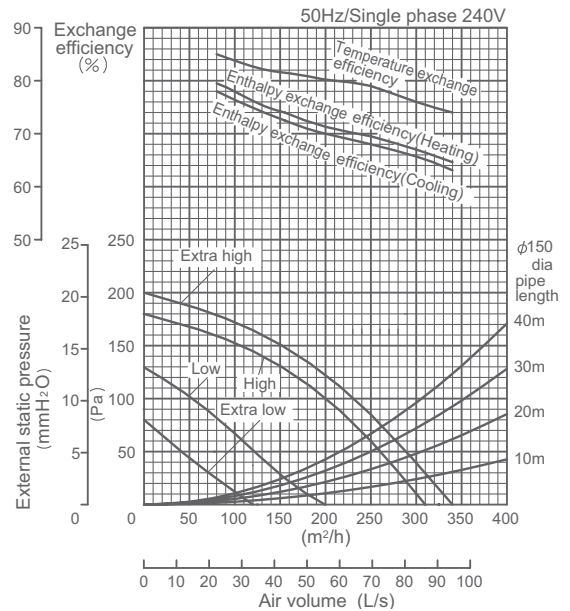
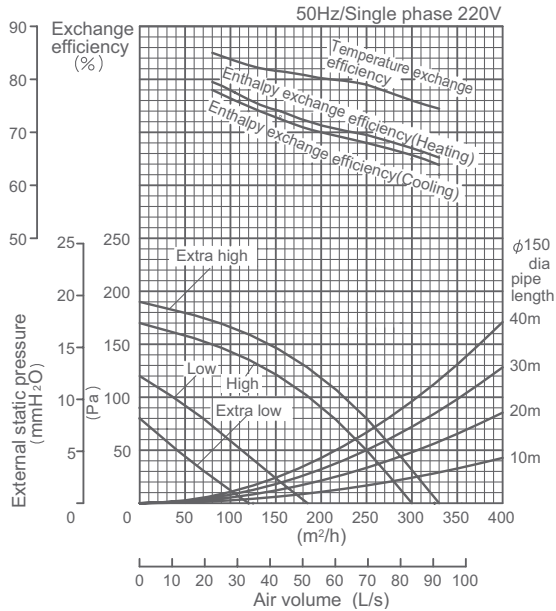

Unit: mm



# LGH-35RX5-E

Model		LGH-35RX5-E								
Frequency / Power source		50Hz / Single phase 220-240V								
Ventilation mode		LOSSNAY ventilation				By-pass ventilation				
Fan speed		Extra High	High	Low	Extra Low	Extra High	High	Low	Extra Low	
Current (A)		0.92-0.92	0.74-0.74	0.5-0.51	0.28-0.3	0.93-0.94	0.77-0.77	0.51-0.52	0.28-0.3	
Power consumption (W)		195-212	160-169	105-116	58-69	197-217	164-173	105-116	58-69	
Air volume		(m <sup>3</sup> /h)	350	350	210	115	350	350	210	115
		(L/s)	97	97	58	32	97	97	58	32
External static pressure		(mmH <sub>2</sub> O)	15.8-16.3	7.6-8.2	2.5-3.1	0.9	15.8-16.3	7.6-8.2	2.5-3.1	0.9
		(Pa)	155-160	75-80	25-30	9	155-160	75-80	25-30	9
Temperature exchange efficiency (%)		80.0	80.0	85.0	88.0	—	—	—	—	
Enthalpy exchange efficiency (%)		Heating	71.5	71.5	76.5	81.5	—	—	—	—
		Cooling	71.0	71.0	75.5	81.0	—	—	—	—
Noise (dB) (Measured at 1.5m under the center of panel in an anechoic chamber)		32-32	28.5-29.5	21.5-23	18	32.5-32.5	29.5-30.5	21.5-24	18	
Weight (kg)		29								
Starting current		Under 2.4A Less								

\*The Air outlets noise (45° angle, 1.5meters in front of the unit) is about 10dB greater than the indicated value.(at High Fan speed)

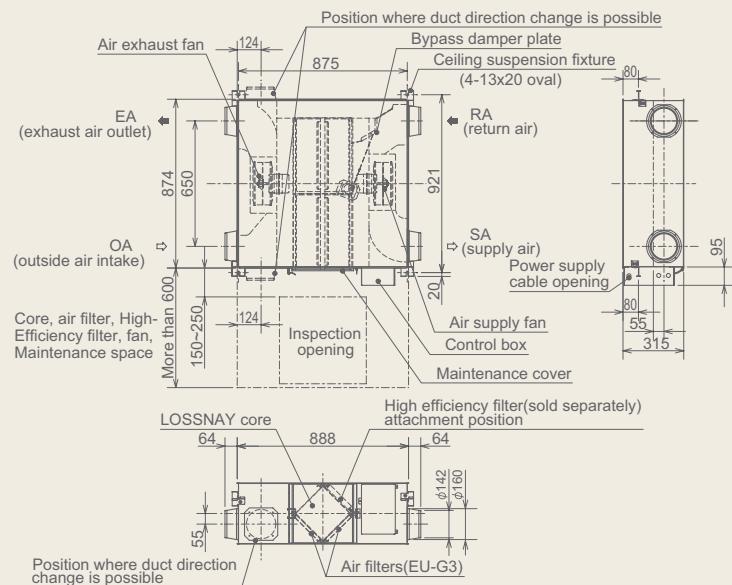
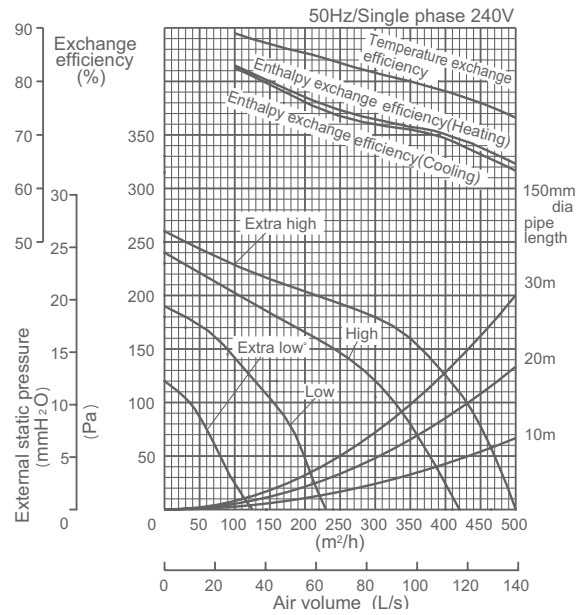
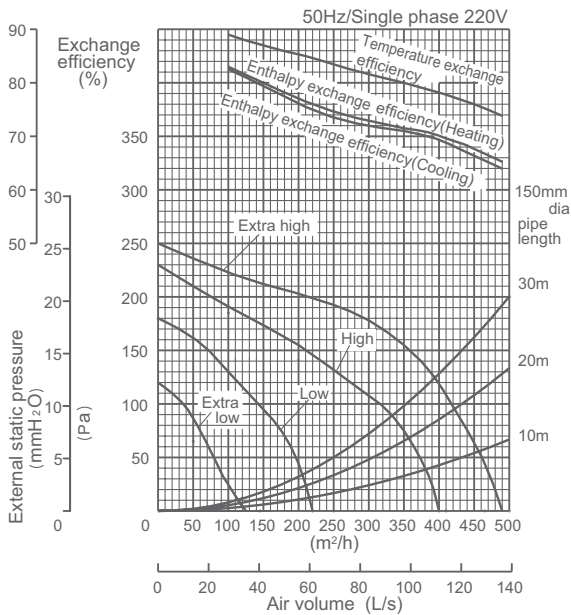

Unit: mm

# LGH-50RX5-E

Model		LGH-50RX5-E								
Frequency / Power source		50Hz / Single phase 220-240V								
Ventilation mode		LOSSNAY ventilation				By-pass ventilation				
Fan speed		Extra High	High	Low	Extra Low	Extra High	High	Low	Extra Low	
Current (A)		1.2-1.25	1.0-1.0	0.85-0.85	0.4-0.4	1.25-1.25	1.0-1.0	0.85-0.85	0.4-0.4	
Power consumption (W)		255-286	207-228	175-190	80-95	260-290	210-230	180-195	80-95	
Air volume		(m <sup>3</sup> /h)	500	500	390	180	500	500	390	180
		(L/s)	139	139	108	50	139	139	108	50
External static pressure		(mmH <sub>2</sub> O)	15.3-15.8	6.6-9.2	4.1-6.1	1.0	15.3-15.8	6.6-9.2	4.1-6.1	1.0
		(Pa)	150-155	65-90	40-60	10	150-155	65-90	40-60	10
Temperature exchange efficiency (%)		78.0	78.0	81.0	86.0	—	—	—	—	
Enthalpy exchange efficiency (%)		Heating	69.0	69.0	71.0	78.0	—	—	—	—
		Cooling	66.5	66.5	68.0	77.0	—	—	—	—
Noise (dB) (Measured at 1.5m under the center of panel in an anechoic chamber)		33-34	30.5-32	26.5-28	19	34-35	31-32.5	27-29	19	
Weight (kg)		32								
Starting current		Under 3.0A Less								

\*The Air outlets noise (45° angle, 1.5meters in front of the unit) is about 16dB greater than the indicated value.(at High Fan speed)

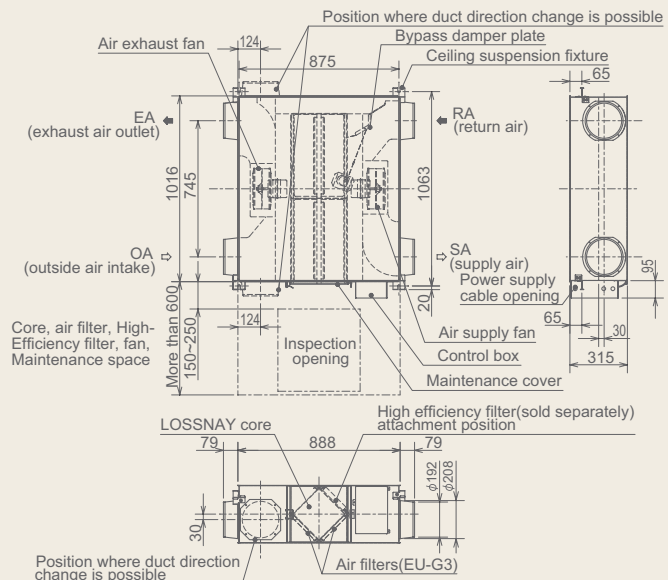
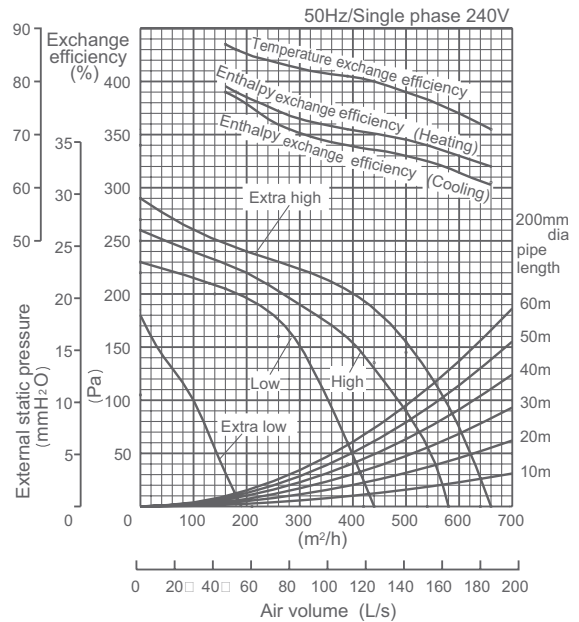
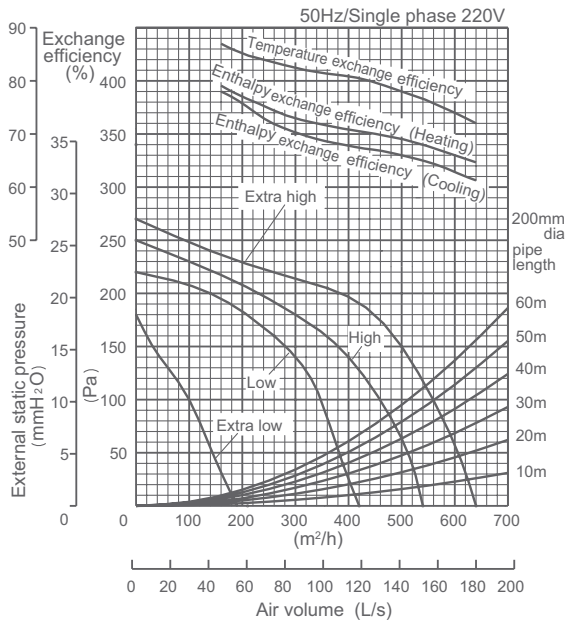

Unit: mm

# LGH-65RX5-E

Model		LGH-65RX5-E							
Frequency / Power source		50Hz / Single phase 220-240V							
Ventilation mode		LOSSNAY ventilation				By-pass ventilation			
Fan speed		Extra High	High	Low	Extra Low	Extra High	High	Low	Extra Low
Current (A)		1.7-1.8	1.5-1.5	1.2-1.2	0.6-0.6	1.7-1.8	1.5-1.5	1.2-1.2	0.6-0.6
Power consumption (W)		350-380	308-322	248-265	120-140	350-385	310-335	250-265	120-140
Air volume	(m <sup>3</sup> /h)	650	650	520	265	650	650	520	265
	(L/s)	181	181	144	74	181	181	144	74
External static pressure	(mmH <sub>2</sub> O)	11.2-12.2	6.1-8.2	4.1-5.1	0.8	11.2-12.2	6.1-8.2	4.1-5.1	0.8
	(Pa)	110-120	60-80	40-50	8	110-120	60-80	40-50	8
Temperature exchange efficiency (%)		77.0	77.0	80.0	86.0	—	—	—	—
Enthalpy exchange efficiency (%)	Heating	68.5	68.5	70.5	78.0	—	—	—	—
	Cooling	66.0	66.0	68.5	77.0	—	—	—	—
Noise (dB) (Measured at 1.5m under the center of panel in an anechoic chamber)		34-34.5	32-33	28.5-31.5	22	34.5-35	32.5-33.5	28.5-30.5	22-22.5
Weight (kg)		40							
Starting current		Under 4.4A Less							

\*The Air outlets noise (45° angle, 1.5meters in front of the unit) is about 10dB greater than the indicated value.(at High Fan speed)

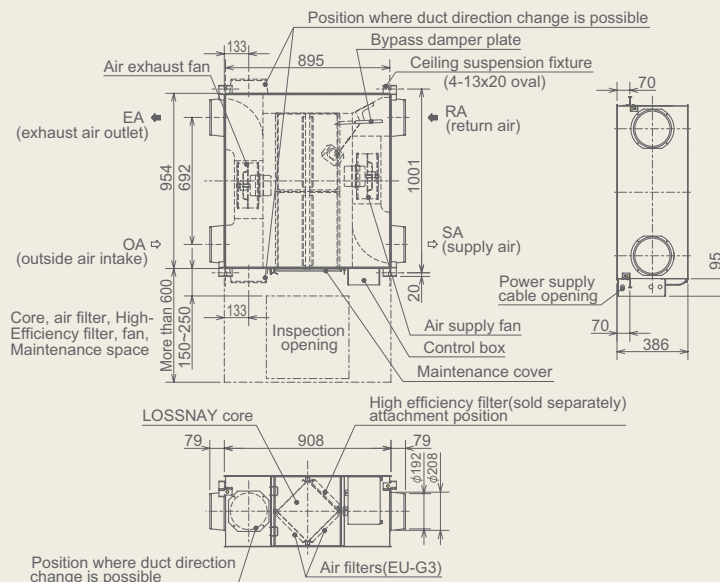
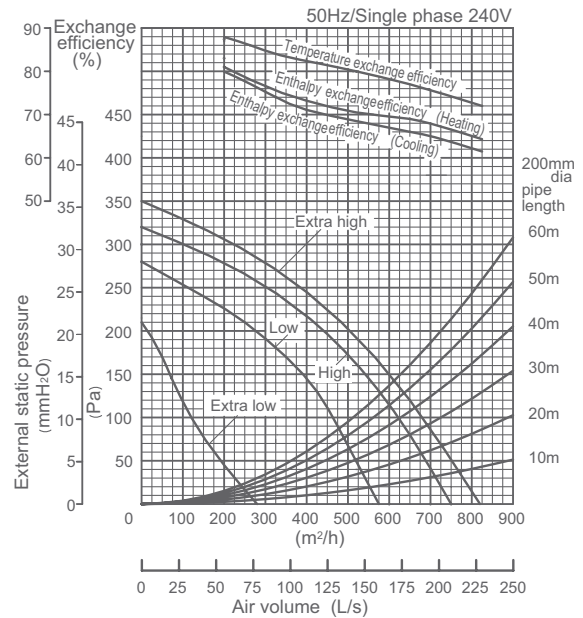
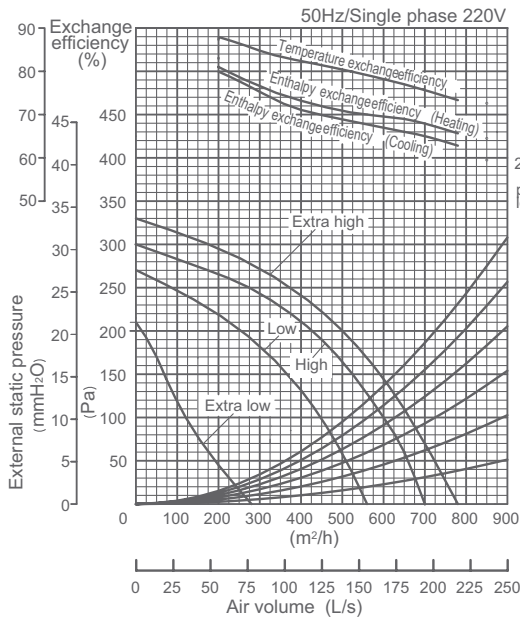

Unit: mm

# LGH-80RX5-E

Model		LGH-80RX5-E							
Frequency / Power source		50Hz / Single phase 220-240V							
Ventilation mode		LOSSNAY ventilation				By-pass ventilation			
Fan speed		Extra High	High	Low	Extra Low	Extra High	High	Low	Extra Low
Current (A)		1.75-1.75	1.6-1.6	1.45-1.45	0.60-0.65	1.75-1.75	1.6-1.6	1.45-1.45	0.60-0.65
Power consumption (W)		380-415	345-370	315-340	125-145	380-415	345-370	315-340	120-145
Air volume	(m <sup>3</sup> /h)	800	800	700	355	800	800	700	355
	(L/s)	222	222	194	99	222	222	194	99
External static pressure	(mmH <sub>2</sub> O)	14.8-15.3	10.7-12.2	8.2-9.7	2	14.8-15.3	10.7-12.2	8.2-9.7	2
	(Pa)	145-150	105-120	80-95	20	145-150	105-120	80-95	20
Temperature exchange efficiency (%)		79.0	79.0	80.5	87.5	—	—	—	—
Enthalpy exchange efficiency (%)	Heating	71.0	71.0	72.5	79.5	—	—	—	—
	Cooling	70.0	70.0	71.5	79.5	—	—	—	—
Noise (dB) (Measured at 1.5m under the center of panel in an anechoic chamber)		33.5-34.5	32-33	30-31	22	34.5-35.5	33-34	31-32	22
Weight (kg)		53							
Starting current		Under 3.8A Less							

\*The Air outlets noise (45° angle, 1.5meters in front of the unit) is about 16dB greater than the indicated value.(at High Fan speed)

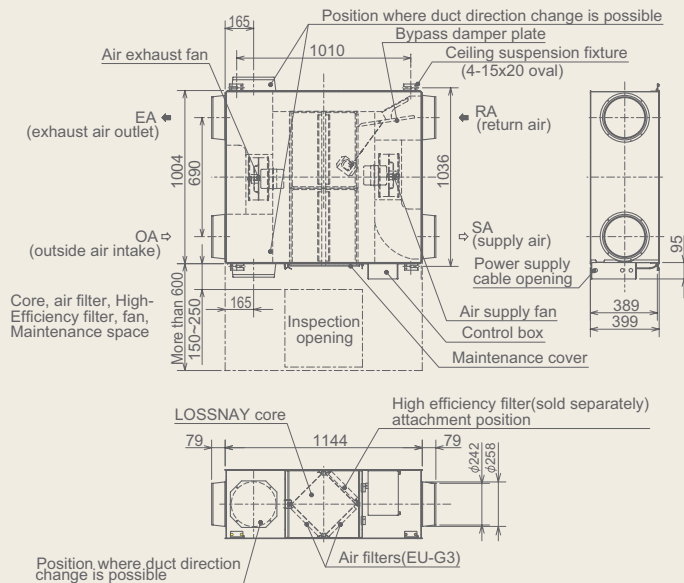
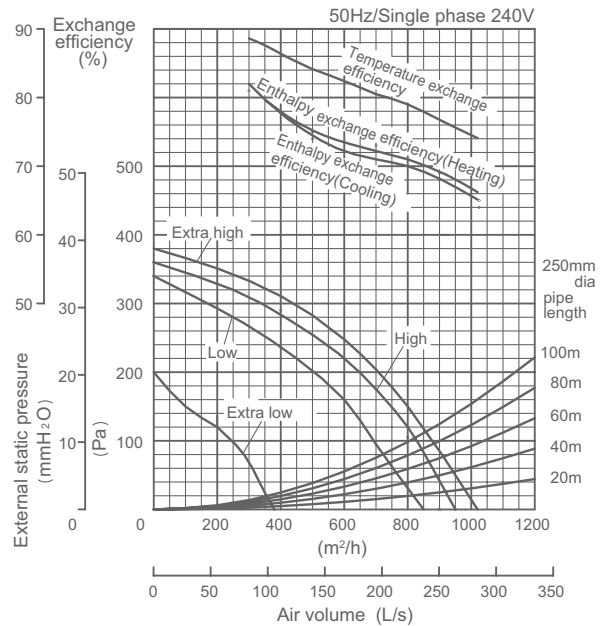
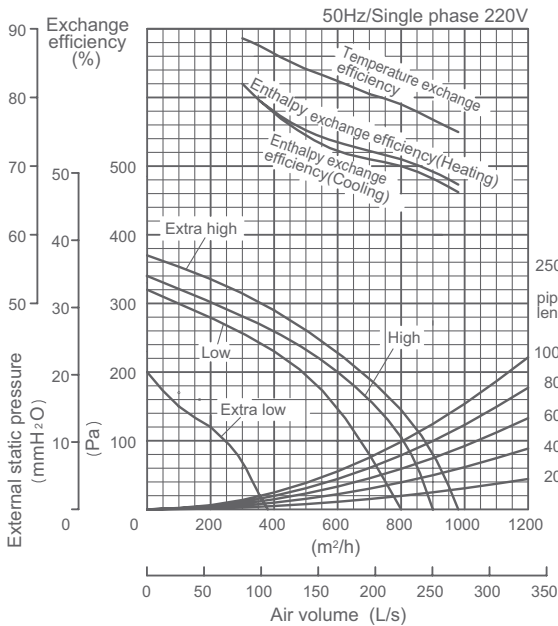

Unit: mm

# LGH-100RX5-E

Model		LGH-100RX5-E								
Frequency / Power source		50Hz / Single phase 220-240V								
Ventilation mode		LOSSNAY ventilation				By-pass ventilation				
Fan speed		Extra High	High	Low	Extra Low	Extra High	High	Low	Extra Low	
Current (A)		2.3-2.4	2.1-2.1	1.7-1.7	0.9-0.9	2.3-2.4	2.1-2.1	1.7-1.7	0.9-0.9	
Power consumption (W)		500-535	445-475	350-380	175-200	510-550	460-485	365-395	175-200	
Air volume		(m <sup>3</sup> /h)	1000	1000	755	415	1000	1000	755	415
		(L/s)	278	278	210	115	278	278	210	115
External static pressure		(mmH <sub>2</sub> O)	16.3-17.3	10.2-11.2	5.6-6.1	1.8	16.3-17.3	10.2-11.2	5.6-6.1	1.8
		(Pa)	160-170	100-110	55-60	18	160-170	100-110	55-60	18
Temperature exchange efficiency (%)		80.0	80.0	83.0	87.0	—	—	—	—	
Enthalpy exchange efficiency (%)		Heating	72.5	72.5	74.0	80.0	—	—	—	—
		Cooling	71.0	71.0	73.0	79.0	—	—	—	—
Noise (dB) (Measured at 1.5m under the center of panel in an anechoic chamber)		36-37	34-35	31-32.5	21-22	37-38	35-36	32-33	21-22	
Weight (kg)		59								
Starting current		Under 4.6A Less								

\*The Air outlets noise (45° angle, 1.5meters in front of the unit) is about 17dB greater than the indicated value.(at High Fan speed)

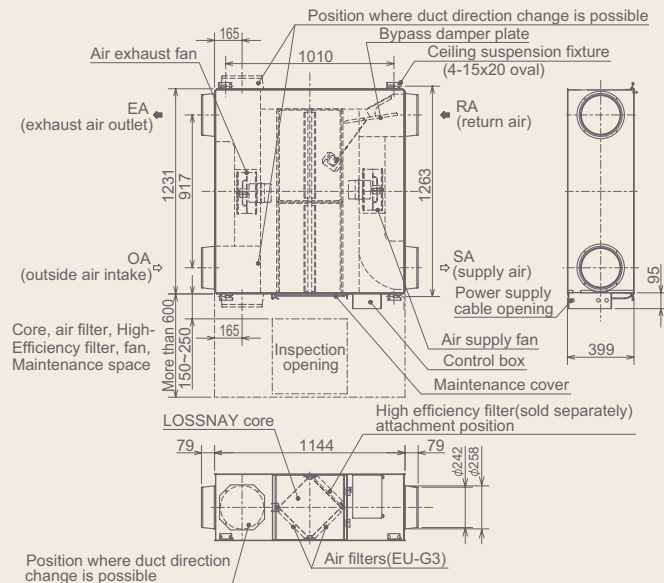
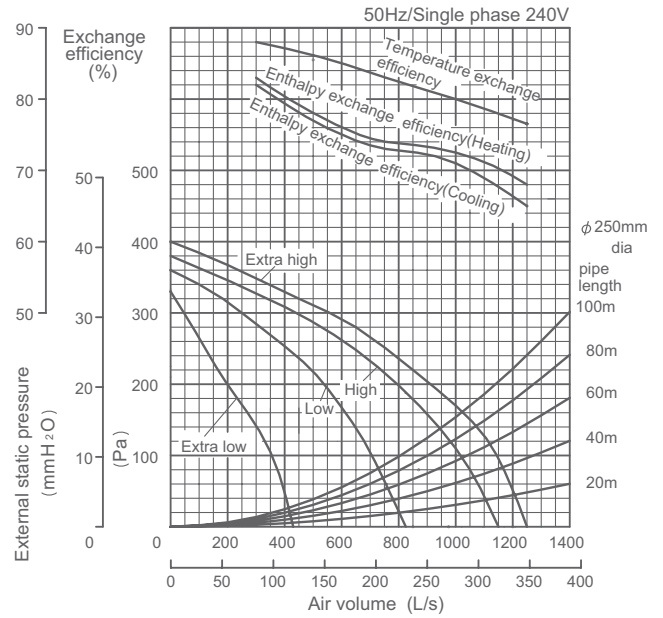
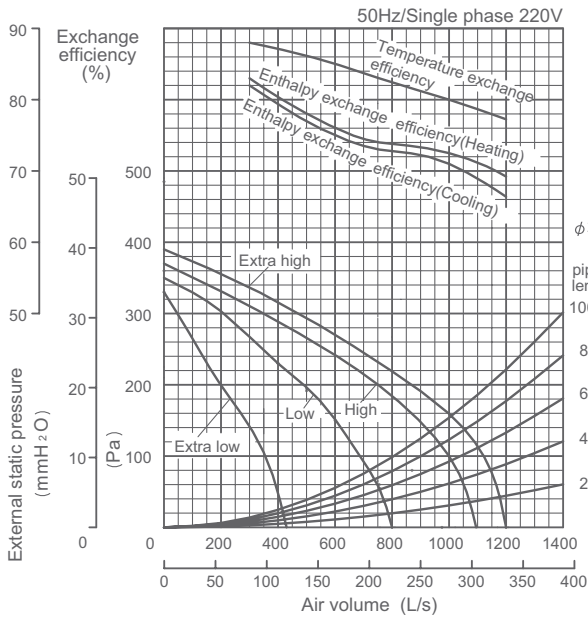

# LGH-150RX5-E

Model		LGH-150RX5-E					
Frequency / Power source		50Hz / Single phase 220-240V					
Ventilation mode		LOSSNAY ventilation			By-pass ventilation		
Fan speed		Extra High	High	Low	Extra High	High	Low
Current (A)		3.5-3.5	3.2-3.2	2.9-2.9	3.5-3.5	3.2-3.2	2.9-2.9
Power consumption (W)		760-830	690-740	630-680	765-835	695-745	635-685
Air volume	(m <sup>3</sup> /h)	1500	1500	1300	1500	1500	1300
	(L/s)	417	417	361	417	417	361
External static pressure	(mmH <sub>2</sub> O)	16.3-17.8	13.3-13.8	9.7-10.2	16.3-17.8	13.3-13.8	9.7-10.2
	(Pa)	160-175	130-135	95-100	160-175	130-135	95-100
Temperature exchange efficiency (%)		80.0	80.0	81.0	—	—	—
Enthalpy exchange efficiency (%)	Heating	72.0	72.0	72.5	—	—	—
	Cooling	70.5	70.5	71.5	—	—	—
Noise (dB) (Measured at 1.5m under the center of panel in an anechoic chamber)		38-39	36-37.5	33.5-35	39-40.5	37.5-39	35.5-37
Weight (kg)		105					
Starting current		Under 7.3A Less					

\*The Air outlets noise (45° angle, 1.5meters in front of the unit) is about 19dB greater than the indicated value.(at High Fan speed)

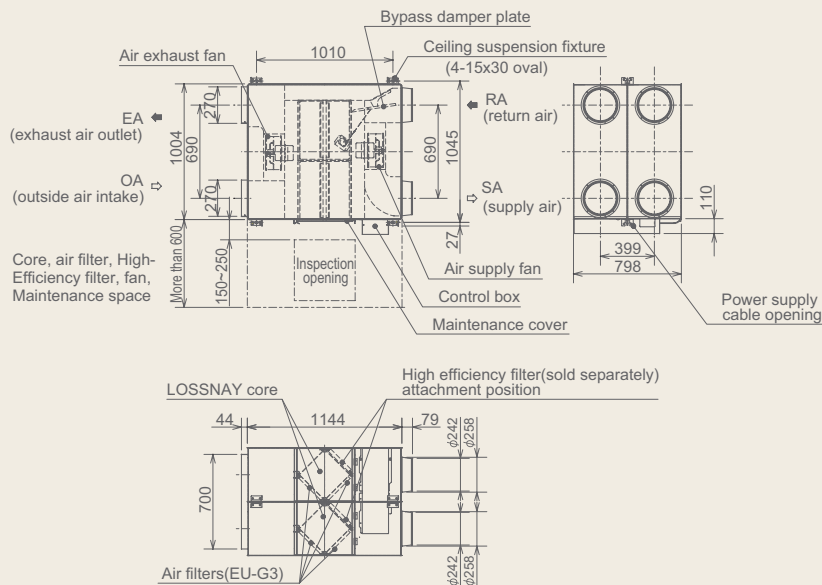
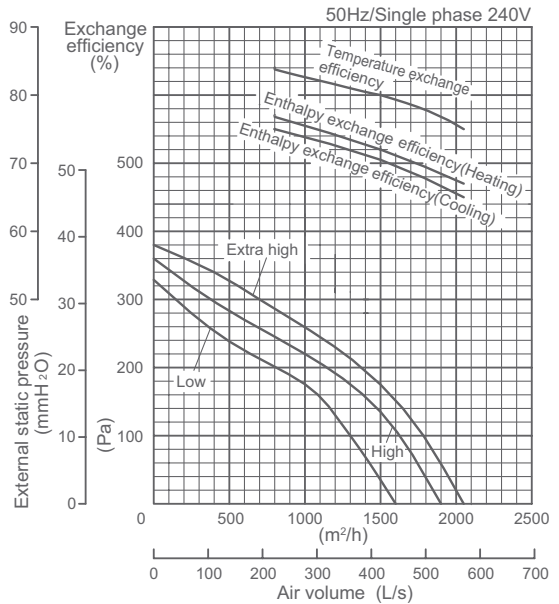
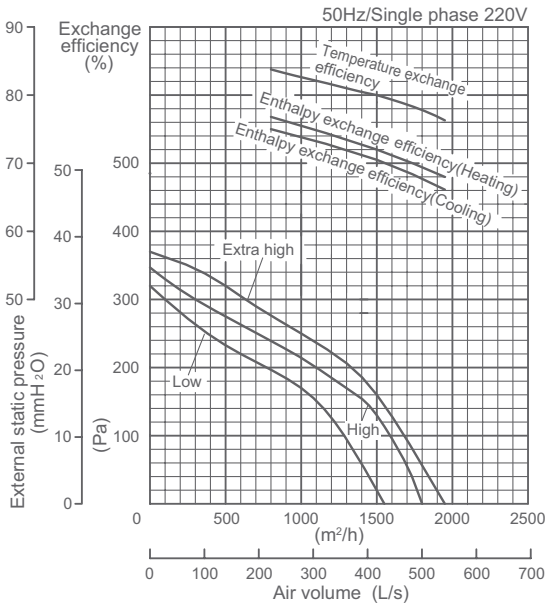

Unit: mm

# LGH-200RX5-E

Model		LGH-200RX5-E						
Frequency / Power source		50Hz / Single phase 220-240V						
Ventilation mode		LOSSNAY ventilation			By-pass ventilation			
Fan speed		Extra High	High	Low	Extra High	High	Low	
Current (A)		4.8-4.8	4.2-4.2	3.4-3.4	4.8-4.8	4.2-4.2	3.4-3.4	
Power consumption (W)		1035-1100	910-980	715-785	1040-1110	915-980	720-785	
Air volume		(m <sup>3</sup> /h)	2000	2000	1580	2000	2000	1580
		(L/s)	556	556	439	556	556	439
External static pressure		(mmH <sub>2</sub> O)	16.3-16.8	10.2-10.7	6.1-6.6	16.3-16.8	10.2-10.7	6.1-6.6
		(Pa)	160-165	100-105	60-65	160-165	100-105	60-65
Temperature exchange efficiency (%)		80.0	80.0	83.0	—	—	—	
Enthalpy exchange efficiency (%)		Heating	72.5	72.5	73.5	—	—	—
		Cooling	71.0	71.0	72.0	—	—	—
Noise (dB) (Measured at 1.5m under the center of panel in an anechoic chamber)		39.5-40	37-38	32.5-34	40.5-41	38-39	33.5-35	
Weight (kg)		118						
Starting current		Under 11.9A Less						

\*The Air outlets noise (45° angle, 1.5meters in front of the unit) is about 20dB greater than the indicated value.(at High Fan speed)

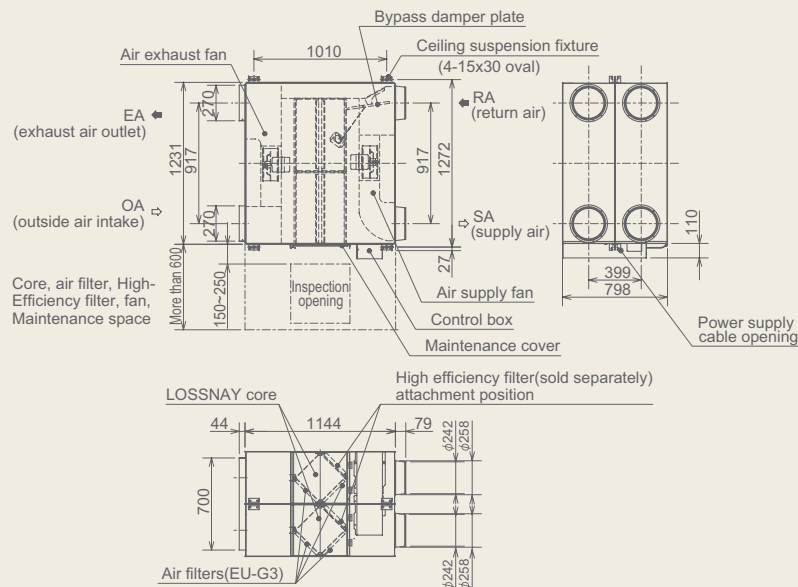
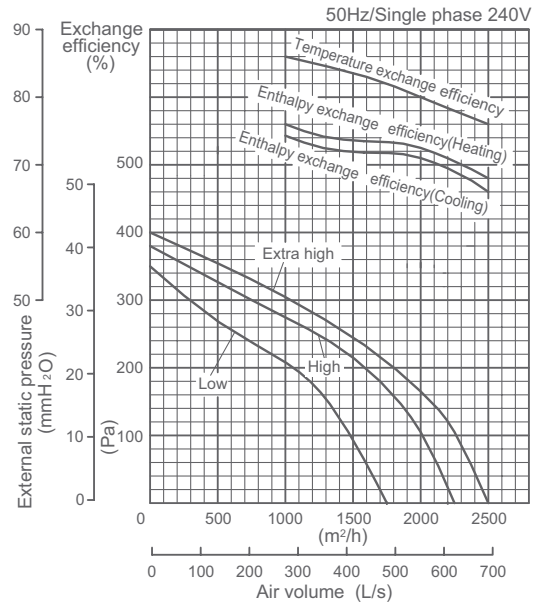
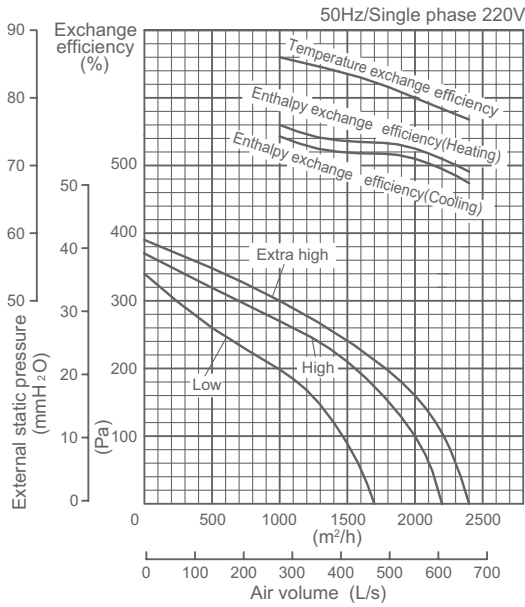

Unit: mm

# Wiring Diagrams

## LGH-15RX5 to 100RX5

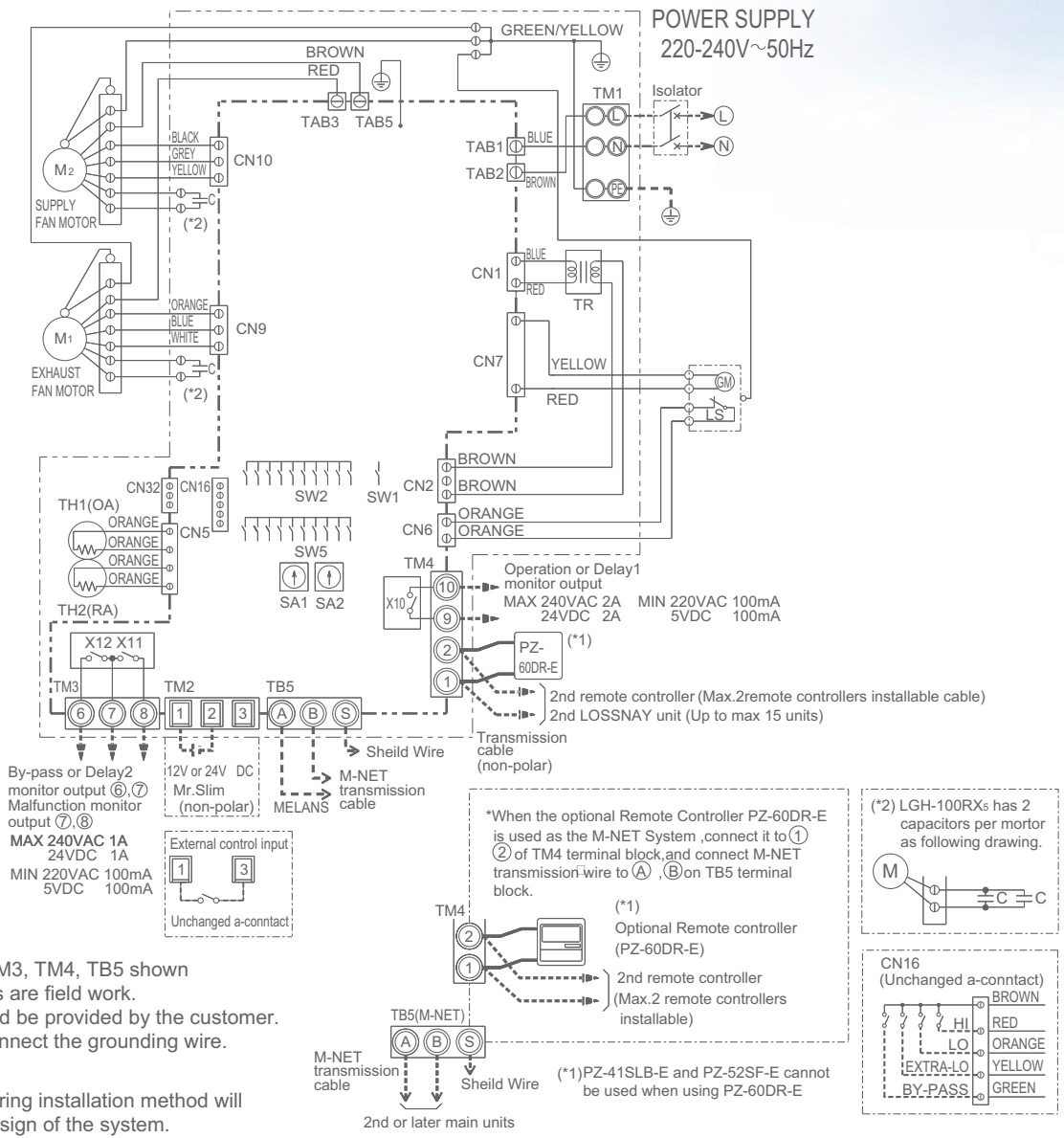

- NOTE 1. TM1, TM2, TM3, TM4, TB5 shown in dotted lines are field work.  
 2. Isolator should be provided by the customer.  
 3. Be sure to connect the grounding wire.

**\*Attention**

With this product, the wiring installation method will vary according to the design of the system. Perform electrical installation to meet local electrical regulations.

- Always use double insulated PVC cable for the transmission cables.
- Wiring work must be performed by qualified professionals.
- All supply circuits must be disconnected before obtaining access to the terminal devices.

\*When the optional Remote Controller PZ-60DR-E is used as the M-NET System, connect it to ① ② of TM4 terminal block, and connect M-NET transmission wire to (A), (B) on TB5 terminal block.

(\*) PZ-41SLB-E and PZ-52SF-E cannot be used when using PZ-60DR-E

(\*) LGH-100RX5 has 2 capacitors per motor as following drawing.

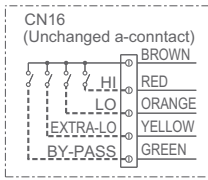

\*Specifications may be subject to change without notice.

Definition of Symbols			
M1:	Motor for exhaust fan	CN1:	Connector (Transformer primary)
M2:	Motor for supply fan	CN2:	Connector (Transformer secondary)
C:	Capacitor	CN5:	Connector (Thermistor)
GM:	Motor for By-pass operation	CN6:	Connector (Microswitch)
LS:	Microswitch	CN7:	Connector (Motor for By-pass operation)
TH1:	Thermistor for outside air	TAB3:	Tab connector(Fan motor)
TH2:	Thermistor for return air	TAB5:	Tab connector (Fan motor)
SW1:	Switch (Main/Sub change)	CN9:	Connector (Fan motor)
SW2, 5:	Switch (Function selection)	CN10:	Connector (Fan motor)
TM1:	Terminal block (Power supply)	CN16:	Connector (High/Low/By-pass switch)
TM2:	Terminal block (External control input)	CN32:	Connector (Remote control selection)
TM3:	Terminal block (Monitor output)	SA1:	Address setting rotary switch (10 digit)
TM4 :	Terminal block (Transmission cable and monitor output)	SA2:	Address setting rotary switch (1 digit)
TB5 :	Terminal block (M-NET Transmission cable)	SYMBOL	○ □ : Indicates terminal block.
TAB1,TAB2:	Connector(Power supply)		⓪ : Connector.
TR1:	Control circuit transformer		Ⓜ : Board insertion connector or fastening connector of control board.
X10,X11,X12:	Relay contact		



# LGH-150RXs and 200RXs

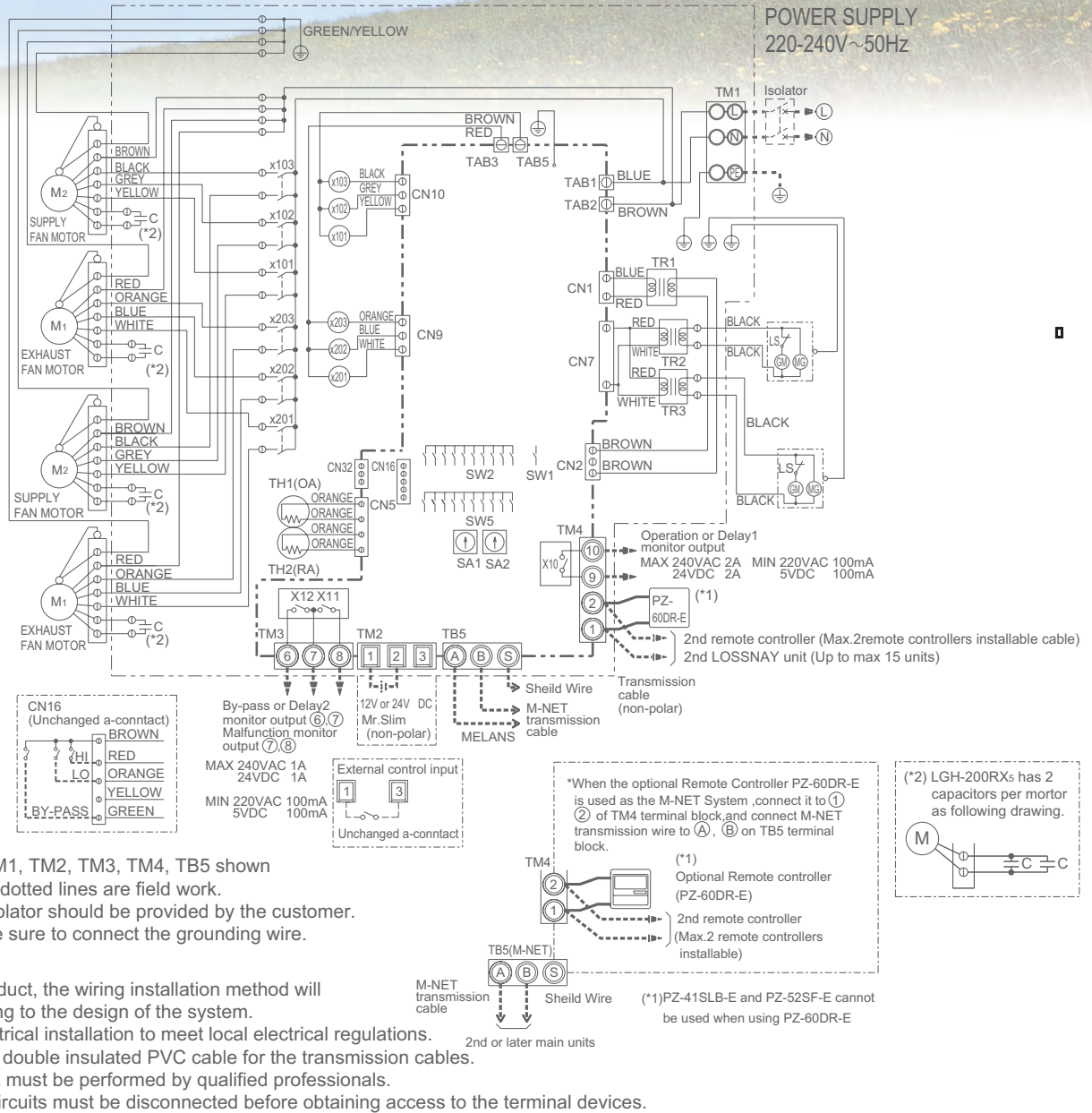

Definition of Symbols	
M1:	Motor for exhaust fan
M2:	Motor for supply fan
C:	Capacitor
GM:	Motor for By-pass operation
LS:	Microswitch
TH1:	Thermistor for outside air
TH2:	Thermistor for return air
SW1:	Switch (Main/Sub change)
SW2, 5:	Switch (Function selection)
TM1:	Terminal block (Power supply)
TM2:	Terminal block (External control input)
TM3:	Terminal block (Monitor output)
TM4:	Terminal block (Transmission cable and monitor output)
TB5:	Terminal block (M-NET Transmission cable)
TAB1, TAB2:	Connector (Power supply)
TR1:	Control circuit transformer
TR2, TR3:	By-pass operation transformer
X10, X11, X12:	Relay contact
X101, X102, X103:	Relay Supply fan speed control
X201, X202, X203:	Relay Exhaust fan speed control
CN1:	Connector (Transformer primary)
CN2:	Connector (Transformer secondary)
CN5:	Connector (Thermistor)
CN6:	Connector (Microswitch)
CN7:	Connector (Motor for By-pass operation)
CN9:	Connector (Fan motor)
CN9:	Connector (Fan motor)
CN10:	Connector (Fan motor)
CN16:	Connector (High/Low/By-pass switch)
CN32:	Connector (Remote control selection)
SA1:	Address setting rotary switch (10 digit)
SA2:	Address setting rotary switch (1 digit)
SYMBOL	○ □ : Indicates terminal block. ⊙ ⊚ Board insertion connector or fastening connector of control board.

# Sample Installations

## LGH-15RX5 to 100RX5

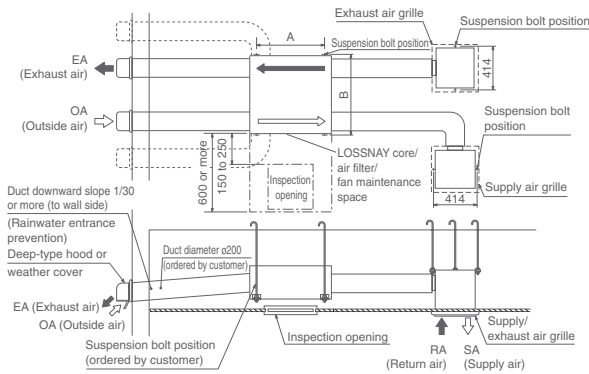

- Always leave inspection holes (□450 or □600) on the air filter and LOSSNAY core removal side.
- Always insulate the two ducts outside the room (intake air and exhaust air ducts) to prevent condensation.
- It is possible to change the direction of the outside air ducts (OA and EA side).
- Do not install the vent cap or round hood where it will come into direct contact with rain water.

Unit: mm

Model	A	B
LGH-15RX5	768	782
LGH-25RX5	768	782
LGH-35RX5	875	921
LGH-50RX5	875	1063
LGH-65RX5	895	1001
LGH-80RX5	1010	1036
LGH-100RX5	1010	1263

## LGH-150RX5 and 200RX5

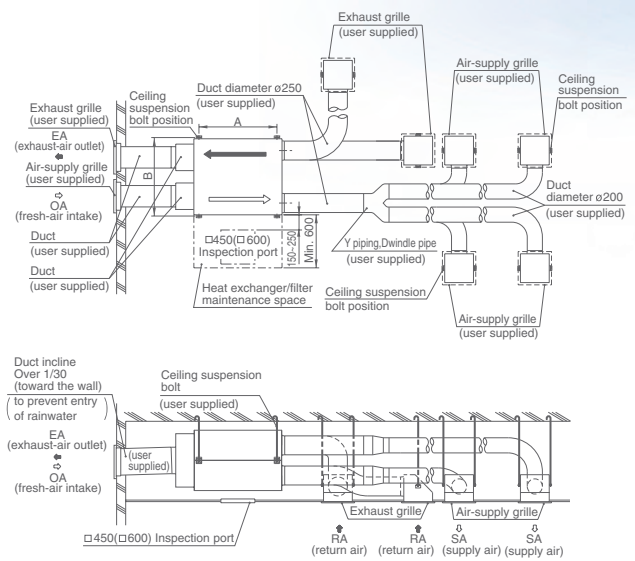

- Always leave inspection holes (□450 or □600) on the air filter and LOSSNAY core removal side.
- Always insulate the two ducts outside the room (intake air and exhaust air ducts) to prevent condensation.
- If necessary, order a weather cover to prevent rain water from direct contact or entering the unit.

Unit: mm

Model	A	B
LGH-150RX5	1010	1045
LGH-200RX5	1010	1272

## Attention for specifications

1. Cold operation mode(\*1) is to start repeating in the case that LOSSNAY's detected OA temperature is less than -10°C.
  - \*1. Supply air(SA) in the operation for 60min. followed by stop operation for 10min.
2. The current, power consumption and efficiency are based on the air flow rate in the specification.
3. Fan speed is selectable by the remote controller from High (Extra-High), Low, Extra-Low(Extra-Low not equipped LGH-150RX5 and 200RX5).
  - Multi Ventilation Mode should set on LOSSNAY unit or remote controller (PZ-60DR-E).
4. LOSSNAY ventilation mode is to start automatically in the case that LOSSNAY's detected OA temperature is less than +8°C, even if By-pass ventilation is set by remote controller.
  - Remote controller continue to show "By-pass ventilation" in this case.
5. Temperature Exchange efficiency(%) are based on winter condition.
6. Mitsubishi Electric measures the machine according to the Japan Industrial Standards(JIS B 8628)

## Attention

1. When using the product where it is exposed to high temperatures and humidity (40°C or higher, RH 80% or higher), or where fog occurs frequently, moisture is likely to condense in the core, and may result in condensation build up in the unit. The product should not be used under such conditions.
2. Outdoor air may enter the LOSSNAY owing to the pressure difference between indoor and outdoor or external winds even when the product is not operated. It is recommended to install an Electrically operated damper to block the outdoor air.
3. In a cold weather area, an area with strong external winds or where fog occurs frequently, cold outdoor air, external winds or fog may be introduced into the product when its operation is stopped.
  - It is recommended to install an Electrically operated damper.
4. In a cold weather area, or others, dewing or freezing could occur on the main unit, where the duct is connected, or other sections, depending on the conditions of outdoor air and indoor temperature and moisture, even if they are within the range of operating conditions. Make sure to confirm the operating conditions and other precautions, and do not use the product if dewing or freezing is anticipated.
5. The outside ducts must be tilted at a gradient (1/30 or more) down toward the outdoor louvres from LOSSNAY, and properly insulated. (The entry of rain water may cause power leakage, fire, or damage to household property)
6. The two outdoor ducts must be covered with heat-insulating material in order to prevent condensation from forming.
  - If it is expected that the ambient temperature around the place where the LOSSNAY unit is installed will be high during the summer air conditioning season, it is recommended that the indoor ductwork be covered with insulation material.
7. Inspection opening (450 × 450 or 600 × 600mm) must be installed on the filter and LOSSNAY core removing side.

## LOSSNAY model selection advices

### 1. Operating environment

Install this product in an environment where the temperature ranges from -10°C to +40°C and the relative humidity is less than 80%RH. If condensation is expected to form, heat up the fresh outside air should be treated.

### 2. Do not use under high temperature and humidity condition

Condensation will occur and water will gather inside the LOSSNAY cores under high temperature and humidity condition, such as warm swimming pool, bathroom, greenhouse or foggy place.

### 3. Condition of outdoor, indoor and return air

Avoid using LOSSNAY under air condition with acid, alkalis, organic solvent, oil mist, paint, or harmful gas as pesticide, corrosive gas, etc.

### 4. Insulation failure caused by salt or sulphur air and hot spring steam, Rust, fire or malfunction may occur.

Installing high quality filters inside outdoor air duct if the LOSSNAY operates in salt or sulphur air conditions.

### 5. Intake of mist or outdoor air during off-mode operation

Outdoor air or mist may flow through the duct into your room when LOSSNAY is in off-mode at windy and foggy area.

To prevent intake of outdoor air or fog, a damper is advised to be installed.

### 6. Entry of insects

When using the product in an environment where there is a window, or opening near the outdoor hood, so that insects are likely to gather around the interior or exterior light, take note that small insects may intrude into the LOSSNAY filters.

### 7. By-pass ventilation

In the case of "By-pass" ventilation, the supply air temperature slightly rises more than the outside air temperature because of the effect around the ducts or the unit motors.

### 8. Usage of M-NET.

When solely using LOSSNAY units, power supply unit is required to connect to centralized control. Number of power supply units or the transmission boosters should correspond with the connected LOSSNAY units.

## Caution for installation

### 1. Do not modify the unit as it may cause malfunction.

### 2. Leaving sufficient space for maintenance purpose.

### 3. The location of the air inlet

Take care in locating air inlet to prevent intake of dirty air or disgusting smell from exhaust gas of factory, air from rubbish disposal, etc.

### 4. Take precautions when using the product in quiet location.

### 5. Heat insulation foam for duct

Take care as below to prevent the contaminate ceiling by duct condensation.

1) The two outdoor ducts (OA and EA) must be covered with heat-insulating material in order to prevent condensation.

2) If it is expected that the ambient temperature around the place where the LOSSNAY unit is installed will be high during the summer air conditioning season, it is recommended that the indoor ductwork be covered with insulation material.

3) Outdoor air may come into unit during not operating unit by the pressure difference between indoor and outdoor or the outdoor wind. In this case you should install a damper.

4) It is possible for condensation and freezing to occur in the cold regions inside the unit because of the outdoor air condition or humidity condition above ceiling. Make sure to install supplemental insulation foam.

5) In the case that air condition around LOSSNAY unit is high temperature in summer, it is recommended that there are heat insulation foam on indoor side duct to prevent heat recovery decreased by warming indoor duct.

In winter, it is possible to cool indoor side duct without heat insulation foam on indoor side duct.

### 6. Prevent entry of rainwater into LOSSNAY unit

Install weather louvre or "Weather cover" for OA inlet & EA outlet. This is to prevent rainwater entering the LOSSNAY unit. Ducts to outdoor (OA and EA) should decline by 1/30 or more.

1) Install the anchor bolts to ensure the product's weight or earthquake load. (Correctly rated wire/chain may also be used)

2) Do not install this product in a place where it is exposed to ultraviolet light. (UV may be damage covering insulation.)

### 7. Electrical Work

A single pole isolator must be installed at the origins of mains power supply.

Use single flush box, to support remote controller.

Must connect ground wiring.

When connecting external devices (electrically operated damper, lamp, monitoring unit, etc.) using output signals of the LOSSNAY unit, make sure to install safety equipment for the external devices.

(It could cause fire, damage, etc. without safety equipment)

